



( )

---

(2010)

/ / / 7

+ (202) 33362721 – 33362719 – 33362724 :

+ (202) 33368293 – 37484902 :

[alo@alolabor.org](mailto:alo@alolabor.org) :

[www.alolabor.org](http://www.alolabor.org) :

.

5	.....
8	.....
9	.....
61	.. :
91	..... : :
129	..... : :
191	..... :
225	..... 2008 :
251	..... :
287	..... :
311	..... :
329	..... :



---

. 2008  
( )

:

.1

: .2

: .3

.4

2008 .5

.6

.7

.8

.9

---

2008

---

2010 /

							**
			. ( )</td <td>-</td> <td>.</td> <td>-</td> <td></td>	-	.	-	
		/		-	.	-	
			/	-	.	-	
			/	-	.	-	
			/	-	.	-	
	/		/	-	.	-	
		/	-	-	.	-	
/		-		-	.	-	
	/	-		-	.	-	
			.	-	.	-	**
		.	-	.	-		
		.	-	.	-		
		.	-	.	-		
		.	-	.	-		
		:					**
		/	-	/	-		
	:		**				**
	/	/	.	-	.	-	
							**
				/	-		
			.				**
				-	/	-	
	/			-	.	-	
				-	/	-	
				-	/	-	
				-	/	-	
				-	/	-	



---

:

---

**-1**

: 2008  
( ) ( )  
) : 2008 " "  
(  
:  
!  
:

**1-1**

2008  
1 2005

62

55

				2009	World Economic Outlook				
2008	%3.0	2007	%5.2						-
			%1.1			2009			
						.%1.3		2010	
					)				-
2008	%0.6	2007	%2.7			(			
2010			%3.4			2009			
						.%1.3			
( "			"		)				-
		2008	%1.5	2007	%5.7				
	.%3.6	2010				%2.4		2009	
	- "		"		-				-
) %1.7		2009				2008	%6.0	2007	%8.3
(			"	"					
						. 2010	%5.1		
									-
						"		"	
-	-	2009	%4.8	: 2008	%6.2	2007			
			.%4.2	2010		%2.0			
				"	"				-
%5.2	: 2008	%6.3	2007			"	"		

---

.%4.0

2010

%1.7 - -  
( )

2009

( )

.( 2008-2003)

( )

-

( )  
. 2009 "

"

- - " "

:

" "

-

-

( )

-

---

3-1

/ )

(98)

(36)

(2009

: ( )

" "

"

"

-

-

" "

" " " " " "

!... - ( )

:

" "

" "

) " "

(" " ) (



: 5-1

... (2010 / )  
" ( 2008  
" ( 2008  
... (2010 / )

Public Policy Guidelines



---

: -2

: 1-2

.1965

):

(

( )

:

(4)

.1967

(2)

(14)

1975

( )

.1981

:

•

•

---

(2020 2010) (2009)  
 15) 2009/1/20 (2008/11/16)  
 (5/ )  
 :  
 )  
 .(  
 :  
 / )  
 (  
 : ( )  
 . 2020  
 ) 1957 -  
 . ( -  
 .( )  
 (2)  
 (4)  
 )  
 . ( -  
 ( )  
 ° ( ) ( )

---



---

( )

( ) •

) •

( ) •

( )

2-2

-

(1) -

1966

(1) ( )

) ( )

(

(2) -

(2) 1967

) 1967

1966 (

---

1975 /

( ) (4) -

.( ) (4)

) ( )

.(

(14) -

: (1981)

( 17/2 ) (4)

) (14) ( )

(

( ) ( ) •

( )

.( 1/5 )

•

:

-



-

-

: (7) (2) -

: (7) (4) -

(19)

) (19) (2)

(2)

(

.(4)

(14)

(4) (2)

-

:

-

-

.( )



---

1999

)

.(

(2000 )

(2000 27 . . 1139)

:

(35)

-

-

:

-

-

-

**3-2**

(14) (4) (2)

---

	" :	(8)	(2)	-
	.			
	"			
	(		)	
	)	(4)	(5/1)	-
.	(			
		(14)		-
	:		):	
				-
				-
				-
	:			
	(	)		-
		(	)	-
	(	)		-
	(	) (	) (	)
(	)			
(	)			-
	/	) (	)	
			(	

---



-

:  
( )  
.( )

-

-

-

:

-

-

:

(15 6) ( )

:

( ) ( ) /  
( ) ..... ( ) ( )  
(16) /

:

-

-





-

-

-

-

-

**4-2**

-

-

:

/ •

1

/ •

-

-

-

-

-



---

(12)

(27)

2003

(1966 27 )

(258)





:

-

( )

/

-

-

(44)

:

:

-

:

-





: -

-

:

:

:

:

(143)

(4)

:

-3

1-3

ã

:  
:"  
:

"

)"

:

o

"

.(

"

":



---

æ

:

2400

<sup>1</sup> ( )

1800

:

<sup>1</sup> ....

:

1.25

2008

1.4

.1999

1

2.6

2

1980

:

( )

■



2000      1980  
 æ  
 .2005    % 3.8      2000    % 4.2    1980    % 12.9

■

...

-

:

1

■

■

:

■

1

(                    2213)

■

(      1807)

-

-

.2005      480 360  
 % 3.8    (      1.2    ) 1975    % 22  
 .(      376.000) 2005

-

"

"

-



.2005 480 360

:

)

(

1

:

( )	
489	
429	
378	( )
<b>400</b>	

:

4000 585

.2005 % 81.1

% 70.6

.2005 % 81.1 2000 % 77.6 1995

% 3.8 376.000

2.240.000 % 2.6 59.000

.2005

% 6.2 2005-1995 183.000

% 3.8

:



---

(284,000)

.(128,000)

)

(157,000)

(35,000)

æ

(85,000) (

% 74

(376,000 )

(278,000)

æ

% 31

.( )

( )

ä

% 5.7

.2008

% 12

æ

---

35,362

:

5747

203,000

% 17.4

( 203,000 )

% 83

0.7 2005 1995

.% 2.4

%

-

....

:

% 3.8

.2005



---

1994

% 23.6

% 26 % 23

2008

% 27.3

1

1

500

( )

1

æ

( )

10,700

( )

.2008

.2008

13000

<sup>1</sup>( )

<sup>1</sup>(...

)

1

---

( )

-

( )

.(endogène)

:

æ

•

...

1

•

**2-3**

1987

:

---

1992

1984

o

2005

---

-  
-

( - )

2005

-

( WTO )

( PRSP )

**-4**

**1-4**

( Productivity )

---

2-4

125 2007  
2007 %39.2  
%70.7 %71  
15 2007 2006  
%28.1  
%25.2 . %67.5 %33.4  
. %9.4 %15.4  
(%59.4)  
%15.4 (%25.2)  
.2007 %25.2 1995 %33.6  
2007 %28.1

3-4

2008  
1899 2007 1505  
2007 %15.1 %26.2 2008  
. 2007 2009  
%14.2 2008 103.4  
%5.4 ( ) 2007

---

									2008
2008	%29.3								
.				%7.8	%13.1			%20.4	
			2008						
319	2008	%11.6							
					735	441			2008
126							384		146
									<b>5-4</b>
735.3		993.3	2008						
				.%35.1		2007			
		.2007		%48.9			%52.3		2008
	2008	%43.4					%38.6		
				2008	%20.2				
				. 2008	8.9	2003			
%15.4									
:									
2007	%48.9								
							.2008	%52.3	

---

)

(.....

.2008 %36

%59.4

%86.7 %83.7

%75 %70.8

7,000

**2008**

**-5**

â

---

(2008)

(1989)

:



---

-6

1-6

-

Explicit  
Learning Outcomes

Implicit  
Level Descriptors

."

":

-

1

Subsystems

■

1

■

1

■

1

■

■

2-6

:

.( ) 8

( ) 1

8

: Descriptors

Factual ( )

:

●

Cognitive /

:

●

Manual

---

Autonomy : : ●  
Responsibility .

10 .2003

#### Qualification Characteristics

: Kind Breadth : ●  
Selectivity Range : ●  
الكفاية وصنفت في: مجال أو سياق الكفاية Context ، ودور الكفاية Role ، وتعلم كيفية التعلم، والتبصر Insight

: 5 12

( )

: 15

● مؤهلات التعليم العالي  
● مؤهلات التعليم العام (المدارس)

3-6

( )

.2009 2130

---

Responsibility      Autonomy      Complexity      :      (      )  
Adaptability

:

- 
- 
- 
- 

4-6

1

1

1

1

1

1 (      )

:

<sup>1</sup> 2008

<sup>1</sup> ISCED 97

1

- 
- 
- 
- 
- 
- 
- 
- 
- 
-

-

Criterion reference

Job performance standards

Training performance standards

( )

6-6

Purpose

-

: /

.( )

▪

•

•

▪

.( )

▪

▪

▪

---

2008

Regulated Occupations

( )

Labour extensive

)

(

:

---

( )  
(2008 )

Occupational Profile

Model

( )

-7

1-7

58 (2009)

50 .  
2020  
%95

%28  
2010

18-15

%60

.(2008

/ -

%26 2006

3

1999

---

				%18					%10	
			%76	:						
		(6)							-	
	7					12-6				
. 1999		%14		2009					2006	
%81										
	%40									
.%97									2006	
	2015		4							
									-	
			18-12	(6)						
2006		28							2009	
1999	%60					. 1999	%24			
			.%59	%52				2006	%68	
				. 2005	%92					
							%48	%73	%70	%76
										<b>2-7</b>
	2008		395							
		%48								
7						30				
						2009				
		.1999				%36			2006	
						. 2006	%22			
	%48			%9.4		%3.5		%2.4		

---

---

%2.5

% 25-20

**3-7**

-

"

/

-

( 9 )  
/

/

-

"

"

"

"

**4-7**

-

-

-

-

-

-9

-

-





---

2010

-

-1

-2

-3

-4

-5

-6

-

-1

-2

-3

-4

-5

-6

-8

1-8

-

1

385

2015

. 2005

%20.3 :

( )

-

(64 - 15)

(64 - 15)

%60

-

%76

<sup>2</sup> 2005 - 1990

%24

%14.7

%14.5

%12.1

:

%20

.%17.0

%15.5

% 15.1

-

% 73.5

%39

<sup>1</sup> المصدر : تقرير التنمية البشرية لعام 2008 ص 231 و 233 .

<sup>2</sup> المصدر : تقرير تنمية القوى البشرية فى الوطن العربى - الصادر عن المنظمة العربية للتربية والثقافة والعلوم ص 38

	%60	%9.6						
		(5)						-
		%3						
		1						
					12			
						:		<b>2-8</b>
								-
		%10.34	2006	2000				
								-
2,080,663	1999							
4738823	2005						%77.3 :	
							%88.4 :	
								<b>3-8</b>
		340						
			200					1300
6500								

<sup>1</sup> المصدر : مجلة التدريب والتقنية – أكتوبر 2005 ( السيد / شفيق الجبر )

---

4-8

:

( )

-

5-8

( )

" "

6-8

:

-

-

-

-

( )

-

National Center for Employment) (

)

-

(Arab

...

-

						-
						<b>-9</b>
						<b>.1</b>
						<b>1.1</b>
% 2.4	2008	334.5				
		3.6				
		.2.5	1.9	2.6		
		15				
	40			4		
				.2020 - 2010		
						<b>2.1</b>
4755						
%10		10	.2008	5858	2007	
		2009		2008	%20	
	.(3)	%.5.3				
						<b>3.1</b>
%4.2		(	)			
		.2005	%3.6	1999		
	11	1.25				

2006-1999

à

%80

2006

%48 %22

.%82.3 32.8

20

%.48

2006

%58

%.7

2006

10.9

( )

10.8

10.2

% 26.3

% 29.9

% 40.5

% 55.4

2005

2005 - 1999

%. 25.7

2006

%28.1

( 15)

%.13.9

( 24-15 )

supply )

(demand driven)

(driven

%20



/

%5

)

%20

:



-2

1.2

39.2

128

2007

2006

%70.7

%71

15

%28.1

.2007

.2007

%56.6





	2007	1995	%3.3	%6	%9
		%7			7
29.9			5		%64
9.8	13.2		13.9		14.8
%25.2			%59.4		.%15.4
		(	)		

%50		%30
	%11	%60

5

%65	%30			
	%63	%40	%35	%30

2.2

<sup>1</sup> ( 2008 - 2007 %14.5 )  
 .2007 %5.7

(7)

<sup>1</sup> المصدر : مصادر إحصائية رسمية عربية وتقديرات منظمة العمل العربية على بيانات متاحة لسنوات سابقة .

---

				4			
.2007	%56.6			%28.1			
	%33.6						
					2007	%25.2	1995
	%30			24-15			
%26.8						.%14.4	
		%94		%17.7		%19.3	
				29-15			
2020		146					
40		%3.4				%2.3	
				2020			
							-3
		:					
							■
						/	
						1(%0.7)	■
		:					
1							●
							●
						1	
							●

---

---

1-3

■

■

●

●

●

●

●

●

●

/

/

Running Start Pre - start :

.Grow and Development /

\* \* \* \* \*

---

:

---

:

2008

( )

( )

2009

" "

" "

:

.

2008

( ) ( ) :  
( ) : 2008 " "

(



( ) : ( 2008

..

:

\*

- %7 -%4  
. %5,5 2010-2009

:

.2009-2008

11

339

435

5,1

3,1

-

-

. (1)

**-1**

2008

-

( )

1

2005

%75

%40

.11 2009/10/15 " " 1





60 ( )  
)" "  
(  
- - !..  
- -  
!.. .. 50  
) " " 2008 / 23  
( ) (

( )  
2001

62  
55  
- " :  
( ) °.. ( ) "  
°..  
°..  
°.  
: °  
:1  
.. ]  
- " " -  
:

[

]:

[ ...

: °..

( )

!" " " " " "

( )

( )

" " ( )

- -

)

.1999

(2 )

(

(2 )

.2006

1997

( )

2007

1975

( )

( %8 )

.<sup>1</sup>

(2 )  
: 1â  
-  
) 2  
.1 ( -  
-  
-  
- ( )  
-2  
( )  
( ) -  
-  
( )  
°.. ( )  
°2008 ( )  
!.. ( )  
( )  
: " " " " -  
1 ( ! ) ( ) °..  
( )

-

°..

( )

( )

( )

( )

1997-1996 ( )

:

"

"

:

-

-

( )

-

( ) :

-

:

" " "



---

1  
1 ( - )

o " "  
" " " "

!..( )

International ( )  
.( )

Clearing Union

- - -

( )

:

( ) ( )

: 1  
( )

" "

( - - - )

.(1939-1919)

			( )		
:			( )		
:					
				( )	
	( )				
.1914	1870				
			( )		
			( )		
(	)		( )		
1971	15	1946			Convertibility
			°..1971	15	
			-		-
			( )		35
- (	)				
(	)	1971		15	
					!..

World :		2009 <sup>1</sup>		Economic Outlook	
2008	%3,0	2007	%5,2	2009	-
			%1,1	2010	-
				2009	-
				2010	-
2008	%0,6	2007	%2,7	2009	-
2010			%3,4	2009	-
				2010	-
				2009	-
				2010	-
		2008	%1,5	2007	%5,7
	%3,6	2010		2009	%2,4
				2009	-
				2010	-
%1,7		2009		2008	%6,0
				2007	%8,3

<sup>1</sup> IMF, World Economic Outlook, October 2009 .





		:	
"	"	"	"
-	-	-	o
"	"	( )	:
:	:	:	:
		1"	" :
:	:	:	:
78,6	( )	%35	-
%67	( )	" "	-
%19		( 34,5) 2000-1999	-
"	"	)	-
78,6		( " "	52,1
%44,6		%66,3	-
		" "	-
		( )	-
(	-	)	-
- <sup>1</sup> .16-2.	2007 (	)	-

:

1

:

( ) %33,3

: %66,6 %33,3

: %66,6

( )

1

( )

"

"

%30,8

( )

- " " - ( )

)

:2(2004

: 3

- %20 -

1 %27-

[..

( )

---

-<sup>1</sup>-

1-2. : 2004 21-19 : ....

-2-

<sup>2</sup>.6

1

-<sup>3</sup>.5

: —  
1.

:

- -

)

(

( )

.2006-2000 1999-1990 :

%17,6 -

30,4

34,7 %18,3

%36,2 %41,4

.2 8,1 8 : ( )

( ) •

- -

%60,8 2004 %26 1990 %25,9

%47,6

.3%51,6 %56,8

( )

]:<sup>4</sup>

" "

.[

United Nations Development Program and League of Arab States, Development Challenges in the Arab Countries: An <sup>1</sup> Alternative Approach, Cairo, May 2008, PP.24-45.

<sup>2</sup> -Ibid, table 3, P.25.

<sup>3</sup> - Ibid, Table 4, P.28.

<sup>4</sup> -Ibid, PP.29-30.

	( )	( )		
	-	-		•
			1998-1996 %33	2007 %23,5
. <sup>1</sup> ( )				%25
	-	( )		•
<sup>2</sup>				
.(	%48	) %33,8	" "	
-			%68 -	
		!..		
"		"		•
-	-			
	)			
)		.(		
		(		
				•
	"	"		

Ibid, P.31. -<sup>1</sup>

- <sup>2</sup>

-3

" " " " " "

(2009 )

(36)

(98)

(2009 / )

" "

" (2009/10/12-19: ) "

:



---

	:		-1
2008	/		
.2006		%14	
4			
.2013	80		
	" "		
.		2008	
			-2
		%55	
		. %66	
15	)		
	( 24-15)		( 24
66	2006		%21
		32,1	33,8
			-3
	" "		

---









( )  
 " "

( ) ( ) !..  
 ( ) ( )  
 - " " -

( )  
 ( )  
 ( )

" " -  
 1944

.1994

( )

)  
 1776 ( °!..  
 .( )  
 ( ) å  
 .( ) ( )

2002 ( )  
 ( )  
 1997

( ) " "

1 " .

%26 700

2( 300 ) 550

\*\*

!..

" " ( !. ) ( )

.(

: - . [ 3

) (" " ) - ( ) " " ( " "

!.. ( ) !.. ( )

!.." "

( ) ( )

10 2008 5 -1

.10 2008/10/5 -2

24 2008/11/20 " " : -13

( )

" "

1944

!.( )

( - )

2008

15

]

.1 2008/11/17

" "

:[

"

"

"

"

2009

" "

-

( - )

- 2009

-

25 24

( )

"

"

:

( )

2,5

:

586

-

- "

"

"

"

)

" "

" " )

(

(



)

(

-5 :

(2008 / )

" "

... (2010 / 18-16)

1

..

:

)

( ) :

( +

( )



Public Policy

Guidelines

" :1" " : \_\_\_

" (2009/10/21-19: )

" "

:

1 -1

1 -2

" "

-3

2009/10/21-19 : " " : -1

.)

---

: 1 -4

-

:" " -

1 " " -5

:

" " -

-

: 1 -6

-

" "

\* \* \* \* \*

---

:

---

---

:

( ..... )

( ) ( )

( )

( )

( )

( )

**-1**

**1-1**

( )

( )

( ) ( )

1964

1957/6/3

---

)

(3/1)

.(

(

)

(1)

(2)

(

)

1965

)

.(

(

)

)

(3) (

):

(

( )

:

.1967

(2)

1975

( )

(4)

(14)

.<sup>(4)</sup> 1981

---

(5)

-

-

•

•

(2020 2010)

(2009)

**2-1**

( )

:

---

2009/1/20

(2008/11/16 15)

(5/ )

:

)

.(

:

/ )

.(

:

) 1957

-

(

( )

( )

-

.( )

(2)

(4)

/ )

(

---

( )

( )

)

( )

-2

.1971

1-2

(1)

-

1966

(1)

( )

)

(

)

(

(8)

/8

(1)

(2)

(3)

(2)

(2) -

(3) -

(6)

(8) 1976

(2)

) ( )

.(

(8)

(6)

(2)

(2) -

(2) 1967

) 1967

1966 (





:  
 ( ) -  
 ( )

.

( )  
 ( ) ( )

: -

- ) •
- .( 1 ) .(
- ) •
- .( 4 ) (
- : •

6 ) .

.(  
 (7)

:

1973

- -

( )

•



---

( 5 )

( 3 )

(<sup>6</sup> 8 )

( )

.1975

( )

(4)

-

1975 /

.( )

(4)

)

( )

.(

(143)

(4)

(

)

(<sup>7</sup> 1975 /

)

.(

: (4)

: (2)

(4)

-

2/2 )

•

.(

•

.( 11/2 )

(2)

) (12/2) (4)  
 .(  
 .( 7/2 ) •  
 (2) (4) -  
 :  
 ) •  
 :  
 .  
 .(2) •  
 :  
 ) (5) -  
 .  
 -  
 (13) (6/2) -  
 (143)  
 )  
 .(8) ( (6)  
 (7/2) (143) ( /12) -  
 ) (4)  
 .(

---

:

) (4) (8/2) -  
.(

(4) -

(4) -  
( )

:

) •  
(  
)  
(

/ •  
(9/3) (1/3) (5/1)

•

---

•

( )

(14)

-

:

(1981)

-

( 17/2 )

(4)

)

(14)

( )

-

(

( )

( )

-

( )

( 1/5 )

-

:

•

•

(14)

( )

---

(4) (2)

:

( )

:

-

-

-

**2-2**

:

(7)

(2)

-

:

(7)

(4)

-

(19)

)

(19)

(2)

(2)

(

.(4)

(14)

(4) (2)

-

-

(<sup>9</sup>)

1999

)

.(

(2000 )

.(2000 27 . . 1139)

-

-

-

---

( )

-3

(4) (2)

(14)

" : (8) (2) -

."

( )

(10)

) (4) (5/1) -

.(

(14) -

: ) :

-

-

-

28

1976

1965

(11) 1966



---

:

( ) -

): /

(12) (

:

( ) -

.

( ) -

( ) ( ) ( )

( )

.

( ) -

/ ) ( )

(

.

-

:

(13)

( ) -

.( )

(14) -

.

(15)

---

---

-

(15 6)

:

( ) /

.... ( ) ( ) ( )

(16)

/

:

-

-

-

-

-

-

-

-

---

-4

1-4

:

/

1

/

:

:

( )

-

/

:

-

( 1/1 )

1958 (173)

)

.(

(17)

)

(19) (

( )

---

1988 (1)

(76) (75)

( )

:

---

( )

(22)

( )

: (512) (23)

)



.(

:

•

:

:

:

:

:

(513)

) ( )

.(

2003 (12) (20 17) -

:

(18) (17) •

:

-

-

-

-

-







		(25)	(7)	(181)
:				-
				-
			(1)	
	.		.	
				•
(1)				•
				:
				-
				-
				-
(16)				
	(		)	(6) (1)
				1976 1966
:				
1996	(8)		(10)	/



(7) 1999 (21)

-

-

-

2003 (12) (21) / :

(17) )

(17) ( ) (%2)

.(

:

(26) (17) -

) ( ) -

) ( %2

(27) (

%2

---

(28)

3-4

(12)

(27)

2003

(1966 27 )

(258)

( )

(29)

/

(11) 1964 38

1980 (8)

2003/35 (28) 2004 (14)

.2006 (19)

/

)

(28)

(

(30)

:

- 
- 
- 
- 
- 
- 
- 

/

(31)

(32) -

:

) ( )

(

---

( / )

(33)

:  
(34)

(35)

:

:

:

:

:

:

:

---

(36)

(37)

( / )

(38)

/

(39)

(40)

-

-

/

-

-

/

:

:

:

( )

:

:

/

) (2/26)

%75

.(

/

(18) (26)

/

( 10 ) (2003 136 )

(%10)

---

(57)

( )

2006

(41)

(42) :

- 
- 
- 
- 
- 
- 
- 
- 
- 
-



- 
- 

2006 (19) (25)  
... ( )

.(

( )

:

- 
- 
- 

(43)

( ) ( )  
o

:

: \*



(143)

) : (1/8)

.(

(4/2)

( ) (4)

)

.(

2008 (76) (12)

...)

2006 (19)

.(

/

/

(44)

:

\*

:

\*

)

.(

:

(45) / :

---

:

-

:

:

/

:

(46)

:

(143)

(4)

1990

---

(47)

:

- (3)
- 1964 (38) 1962 1
- 1970 (151) 2
- (3/1) 3
- 1981 4
- 1983 1994 5
- ( ) 6
- (2)
- 1978/12/9 7
- (23) 8
- 1999 9
- (12) 10
- )
- (
- :

---

	/	
	/	
( )		
.21	:	11
		12
.( ) ( ) ( )		
		13
( )		
		14
.(QIZ)		
.1996		15
(2006)		16
	.(1997) (2007 1985) (2008 2001)	
(2002) (1993) (1988)		
	.(1997) (1990)	
.213 1979 3	:	17
		18
:	( )	
	.217	

	:	19
	.324 2000 .	
	326 :	20
:	(85) :	21
....		
:	:	22
	.194 193 1984 .	
(65 . 99)	2003/9/11 (1 . 03 . 194)	23
		24
	(34)	25
(96)	1948 (88)	1933
		.1949
.( )	(18)	26
	( )	27
40	2002/11/27	
	/	
.293	402 2003	2003 (12)
(73)	(300)	28
(480)	(2000)	
		29
	:	30
.(		
(10)	(11) :	31

	(18)		1996	(115)	
		2006	(19)	( /23)	
					:
					.
					:
					32
					( /13)
					1426/8/23 51/
					(3/ /18) 1980 (8)
					.2003/35
:	1968	(7)		(5)	33
					)
					.
	1987	(6)			34
			.1968	(7)	
2003	(12)				35
.					)
					(28)
	(28)		(516)	(2/258)	36
					.
	(18)		(33)	(13)	:
			(/23)	(23)	37
					(/12)
(76)	(2)				38
					2008
(:					) :
					.
					:
					39

	.1987	(52)	(14 12)	:	
			(12)	:	
					.2005
	2008	(76)	2006	(19)	:
			41 32 26	:	
.2003	136		(30 27)	:	
			(18)	:	
	.2005	(8)	(28 23)	:	
			.1994	(106)	:
			(26 19)	:	
	2008	(76)	(2)		40
			( )		
		(. . .			)
(. . .					)
	1997	(36)			41
		(.24)			42
			( )		43
	( )	( )			44
( )			( )		
(121)			1987	(6)	:
					2007
	(14)				46
			.61 57		47

\* \* \* \* \*



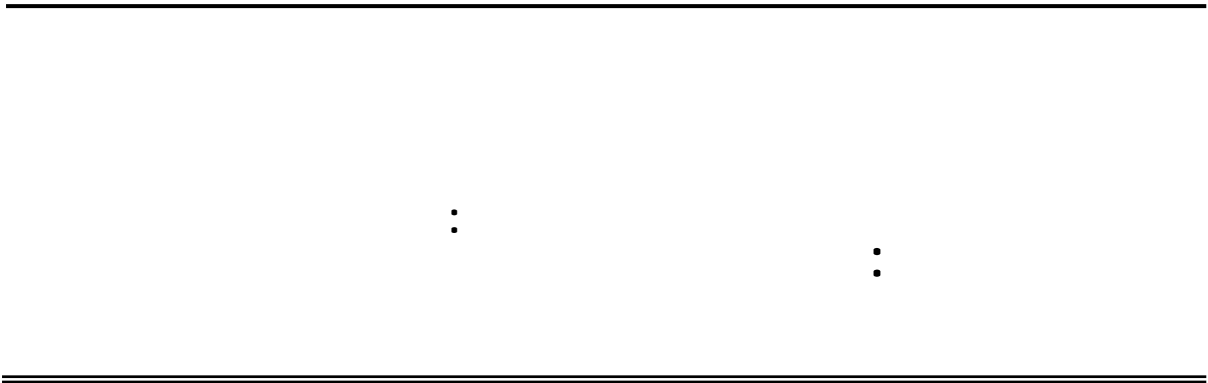

:

:

:

:

1

-

1

71-73 (Spartacus)

-

( 883-869)

-

:

1

1

(les jacqueries)

-

-

1

-

-

-

1

-

-

-

1

-

1995	(OMD)	2015-2000	
		1	-
		1	-
		1	-
		1	-
		1	-
		1 ( )	-
		1	-
			-
æ .		æ	
.1989			
2004			
.2008		2007	

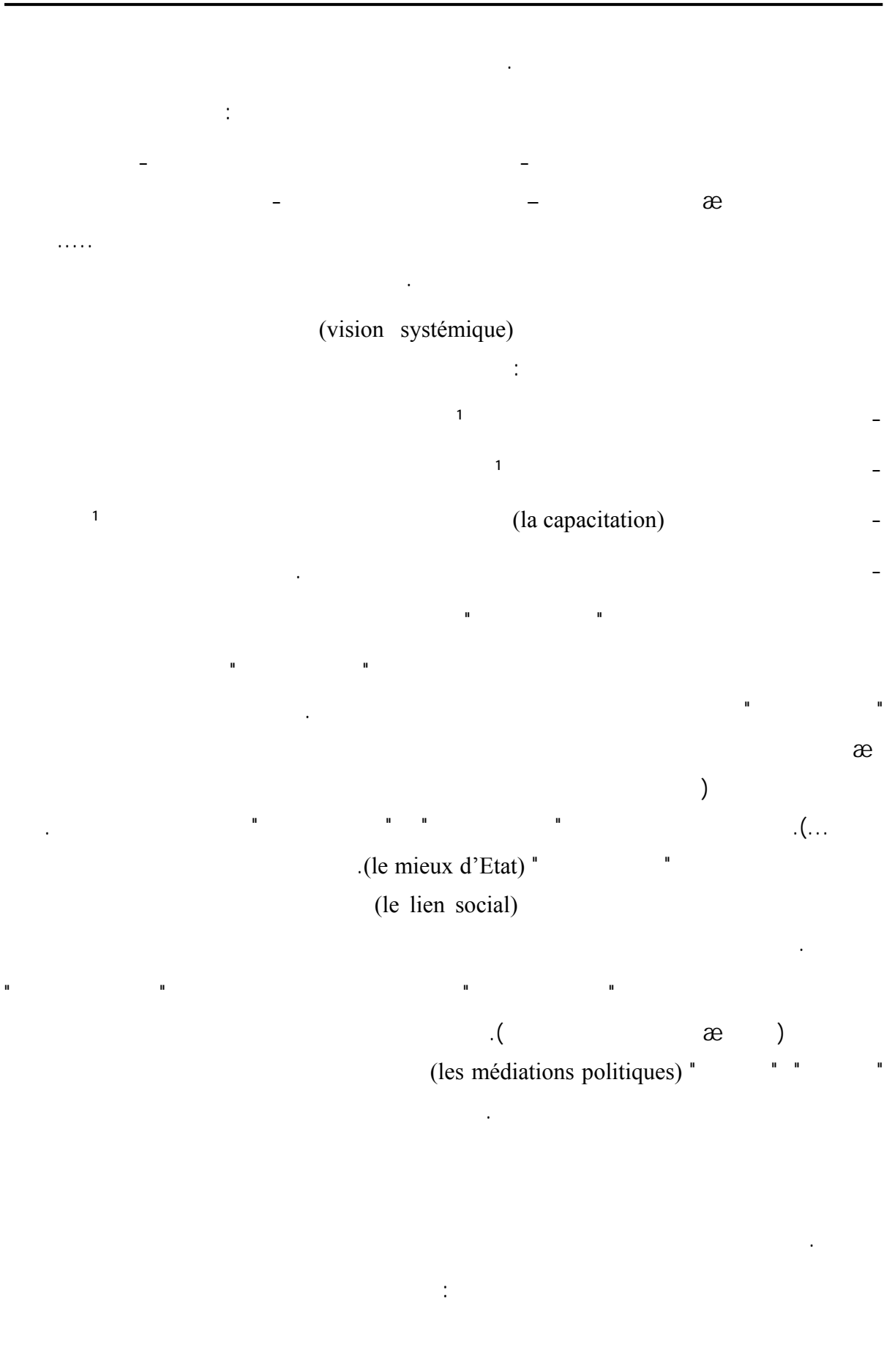

/ / •  
 : / ♦  
 1... ♦  
 1 ♦  
 : ♦  
 ( ) ( ) •  
 ( ) : •  
 •

-1

ã

1-1

" : " ° " : " :  
 ) " : ° " : " :  
 .(

(vœu de pauvreté)

---

æ

2-1

(ST Vincent de Paul)

1

1

1

(Oscar Lewis)

( )

(André Geslin)

( )

"

"

3-1

:

1

1

1

1

1

1

% 60

% 50

.2006

% 7.1

% 50

733

(Pauvreté absolue)

.(Seebohon Rowntree-1901)

4-1



-  
-  
-  
1  
( 2213)  
( 1807)  
-2  
1-2

2005 480 360  
% 3.8 ( 1.2 ) 1975 % 22  
( 376.000) 2005  
.2005 - 1975 (1)

**2005 - 1975**

**: ( 1 )**

2005	2000	1995	1990	1985	1980	1975	
3.8	4.2	6.2	6.7	7.7	12.9	22.0	
376	399	559	544	554	823	1223	(1000)
59	60	84	-	-	-	-	(1000)

2005

:

:

(2)

2005



(2005)

: ( 2 )

1813	2204	2285	( )
1796	2230	2405	( )
1807	2213	2328	

2005

:

:

(2005)

-

400

1.1

1

1999

.

1.25

2008

: ( 3 )

489	
429	( )
378	( )
400	

2005

:

:

(2005)

-

: ( 4 )

21181	128392	1.9	( )
38516	248050	7.1	( )
59697	376442	3.8	

2005

:

:

% 7.8

% 2.2

( )

: ( )

% 12.8

% 3.1

% 2.7

% 1.4

% 5.5

% 3.8

% 1.2

6 5

% 3.1

4

% 0.9

9

% 10.8

8

7

% 8.4

2-2

( )

8211 ä 2005 ä  
 1820  
 1161 2171  
 2005 (5)  
 (2005) : (5)

2171	9367	( )
2431	10091	-
1939	8761	-
1161	5728	( )
<b>1820</b>	<b>8211</b>	

2005 :

4 2005 1820 1985 471  
 2005-2000 20  
 ( ) % 3.8 % 6.5  
 .2000 – 1990 (6)

(2005-1990)

: ( 6 )

%							
2005-2000	2000-1995	1995-1990	2005	2000	1995	1990	/
6.2	5.8	6.7	2171	1604	1209	890	( )
6.1	8.3	5.0	1161	864	581	460	( )
<b>6.5</b>	<b>6.6</b>	<b>6.5</b>	<b>1820</b>	<b>1329</b>	<b>966</b>	<b>716</b>	
3.8	3.2	0.4					

.2005-2000-1995-1990

:

2005

(7)

(2005)

: ( 7 )

2876	4845	2 1
2381	8560	4 3
1669	9003	6 5
1209	8869	8 7
1029	10257	9
<b>1820</b>	<b>8211</b>	

2005

:

:

18000

4500

933 4100

(8)

(2005)

( 8 )

17958	4104	
13139	2851	
8888	1930	
9929	2060	
7133	1456	
6263	1263	
6733	1281	
5133	1020	
4446	933	
9771	2348	
5803	1848	
6259	1659	
8211	1820	

2005

:

:

3-2

% 34.8      2005      634      æ

.% 32.6      % 42.7

2005      (9)

**2005 - : ( 9 )**

(%)	( )	
34.8	634	
22.8	414	
10.7	195	
10.3	188	
8.8	160	
5.6	103	
3.7	67	
2.8	50	
0.5	9	
<b>100.0</b>	<b>1820</b>	

2005      :

**4-2**

:

-

-

:      27 :      :      .      183

78 :      22.7 :      54 :      133 :      9.4

.      18.5 :      7.3 :      70.8 :

1990      % 40      -

.% 4.7

2005 % 34.8

:

2005 -1980

<sup>1</sup> 25

27

•

<sup>1</sup> 10

•

<sup>1</sup> 4

•

<sup>1</sup> 14

•

<sup>1</sup> 60

•

33

•

(10)

30

22

.2005 - 1975

2005-1975

: (10)

2005	2000	1995	1990	1985	1980	1975	
3.4	2.5	1.1	7.0	13.3	9.9	25.5	( )

.2005 2000 1990 1985 1980 1975

:

æ

% 40.1

.2008 % 65.8 1966

.2005 % 10.7 1990 % 7.7

% 21.3 1994 % 15.7

<sup>1</sup>

2008

2005 % 3.7 1990 % 0.5

<sup>1</sup> 2005-2000 % 34.9

1	% 22.8	% 7.7	-
1	% 10.3	% 7.1	-
	<sup>1</sup> 2005-2000	% 5.8	-
		% 5.3	-
	(	)	-
	æ		-

(11)

.2007

:( 11 )

(2007)

(%)		
9.9	10.5	
8.7	8.8	
2.3	2.9	
5.7	5.6	

2005

:

:

(Indice de la masse corporelle – IMC)

-

) ( )

.(

1.60

1.70)

1.64



( 68.3 73.3 65.6 ) . ( 8 30 ) . (12)  
69-20

**69-20 : (12)**

2005	2000	1995	1985	1980	1975	
73.3	70.5	68.6	66.6	65.0	62.7	
65.6	64.9	62.8	61.4	58.8	57.1	
<b>68.3</b>	<b>67.6</b>	<b>65.6</b>	<b>63.9</b>	<b>61.7</b>	<b>59.8</b>	

.2005

)  
69-20 % 83.5 ( (13)

**(2005) - 69-20 : (13)**

*	**	(IMC) **
(%)		
45.4		25 20
38.1		30 26
10.9		30
5.6		20 æ

.2005

(14)

كغ

: (14)

65.6	73.3	*(2005)
62.4	77.4	** (2004)
65.0	79.0	** (-)
68.0	-	** (-)
65	76	** (-)
52.0	62.4	** (-)

.2005

:

\* :

.IFTH : statistique et évolution des mesurations – Paris 2004 \*\*

-3

.2005

480

360

.(15)

2005 - 1975 ( )

:(15)

2005	2000	1995	1990	1985	1980	1975	
400	351	292	222	147	91	64	

:

( )

1

:

: (16)

2005-

489	
429	
378	( )
<b>400</b>	

: :  
.2005

(17)

% 3.8

(2005)

: (17)

(%)	(1000)	( )
<b>3.8</b>	<b>376</b>	( ) <b>400</b>
7.7	776	585 400
19.5	1956	955 585
26.3	2640	1510 955
20.3	2038	2250 1510
15.0	1501	4000 2250
7.4	747	4000
<b>100</b>	<b>10034</b>	

.2005

: :

1-3

4000 585  
.2005 % 81.1  
% 70.6  
.2005 % 81.1 2000 % 77.6 1995

2-3

% 3.8 376.000  
2.240.000 % 2.6 59.000  
.2005  
% 6.2 2005-1995 183.000  
% 3.8  
2005 2000 1995 (18)

: (18)

2005	2000	1995	
3.8	4.2	6.2	(%)
376	399	559	(1000)
59	60	84	(1000)

2005

:

:

3-3

:

-

.2005

2005 - 1975

(19)

**2005-1975 : (19)**

2005	2000	1995	1990	1985	1980	1975	
1.9	4.9	7.1	7.3	8.4	11.8	26.3	
7.1	2.9	4.9	5.8	7.0	14.1	18.0	
3.8	4.2	6.2	6.7	7.7	12.9	22.0	

.2005 2000 1995 1990 1985 1980 1975 :

.2005

.2005 (20)

(2005) : (20)

		(%)	
21181	128392	1.9	( )
38516	248050	7.1	( )
59697	376442	3.8	

.2005 :

(21)

: (21)

(1000)	(1000)	(%)	
1321	7685	0.4	
3657	26348	2.3	
24125	156811	5.4	
8796	59869	5.5	
4315	26564	10.6	
5747	35362	17.4	
11736	63803	2.5	
<b>59697</b>	<b>376442</b>	<b>3.8</b>	

.2005

:

:

2005

(22)

(2005)

: (22)

(1000)	(1000)	(%)	
9441	31036	0.9	4 1
23311	127719	3.1	6 5
19722	145496	8.4	8 7
7223	72191	10.8	9
<b>59697</b>	<b>376442</b>	<b>3.8</b>	

.2005

:

:

4-3

400



1-4

23                      13,000                      86,000

%

% 86                      % 80

.(                      )

.2008                      (23)

(%)                      **2008 -**                      : (23)

2.8	16.0	40.3	40.0	( )
1.5	29.4	39.9	28.0	
2.4	11.5	52.2	34.0	

.2008 -                      :

( )

. % 19                      % 59

( )                      (24)

: (24)

(%)	
59.0	
11.0	
87.0	
17.0	
11.0	
<b>19.0</b>	

.2004 -                      :



% 2.8

( )

(25)

(%)

: (25)

2016-2007	2006-2002	2001-1997	
0.0	0.0	-0.1	
4.4	5.6	4.8	
0.7	0.1	-0.6	
4.7	6.0	5.1	
0.0	0.0	-0.4	
<b>2.4</b>	<b>2.8</b>	<b>2.5</b>	

.2016-2007

2-4

% 31

( )

( )

ä

% 5.7

.2008 % 12

æ

35,362

5747

203,000

% 17.4

( 203,000 )

% 83

0.7 2005 1995

:(26)

%. 2.4

%

:(26)

(%)

2005	2000	1995	
14.9	15.6	15.6 (1994)	
3.8	4.2	6.2	

(Atkinson et coll-1998)

% 15 % 25

æ

(Blank et Blinder, 1986)

1995-1975

5

.1995 1975

(27)

(% )

: (27)

1995		1975		
20.0	8.0	7.5	4.0	
11.0	10.0	7.5	(1980) 8.5	
12.0	8.0	6.5	3.0	

Atkinson et coll : Pauvreté et exclusion sociale, Insee, Paris, 1998 :

(Freyssinet, 1998)

---

" "

.5

:

1-5

.( )

.( )

---

	(Moins d'Etat)	(Plus d'Etat)
(Le Mieux d'Etat)		
	:	
	1	-
	1	-
	.	-
(médiations politiques)	-	-
	æ	æ

	(en aval)	(en amont)
(Théorie de la demande du social) "		"
(Théorie de l'offre du social) "		"
2007		
8211		% 81.1
		1820
		<b>2-5</b>

..... :

---

% 3.8

.2005

% 1.5

1

( )

1

(

1

% 19

300

æ

:

---

						-
% 23.6						
	% 26	% 23		2008	% 27.3	1994
1						
1			500	( )		-
		1				-
						-
					æ	
			( )			
10,700						( )
					.2008	
				.2008		13000
			1 )			
	1 (...		)			-
						-
					1	-
						-
			( )			
						-
			( )			
	(endogène)					
					:	
				æ		•
...						
						1

---







65,4 % 5 2008 80 1999

2008 19.3 %

% 97 .2008 % 93.3 2001 % 83.3

.2008 74.8 2001 72.9 .2011

.2016 77.6 2011 76.5

.2008 % 18 2001 %24.7 ( 10)

2001 % 6.2

.2004 % 0.8 2001 % 1.2 2005 %3.8

2840

8000 2011 5752 .2008 4911 2001

.2016

3 2 1

.( )

:(1)

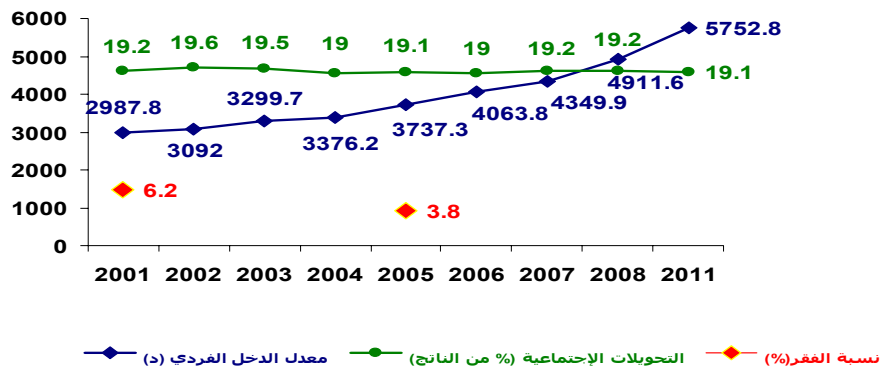

(2):

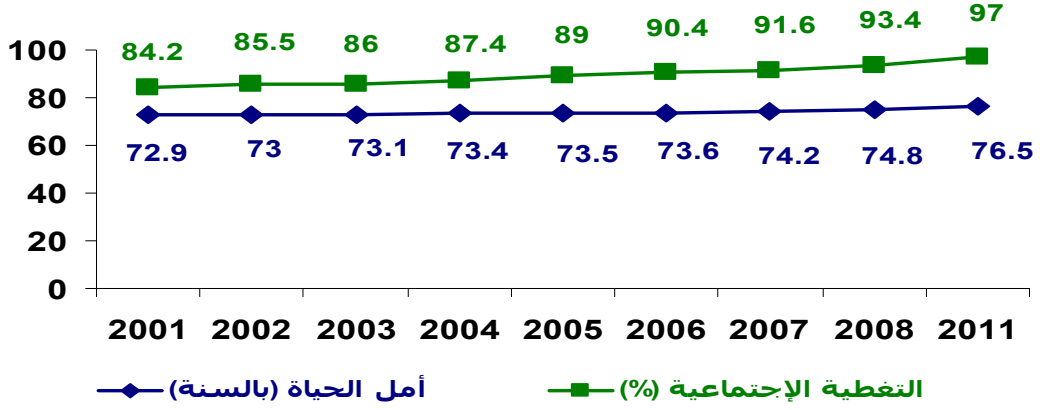

(3):

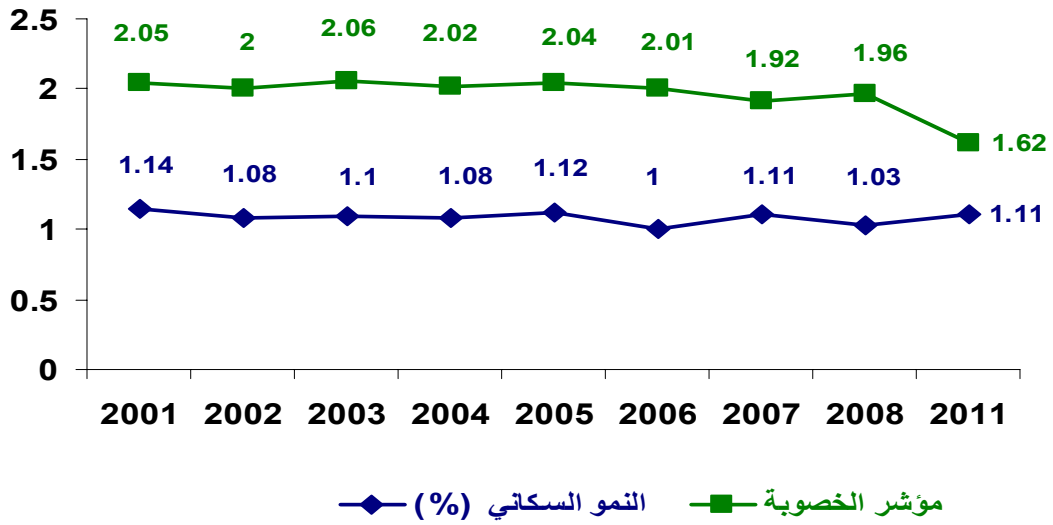

2007      %65.6      ( )  
 2007      % 93      % 99

:(4)

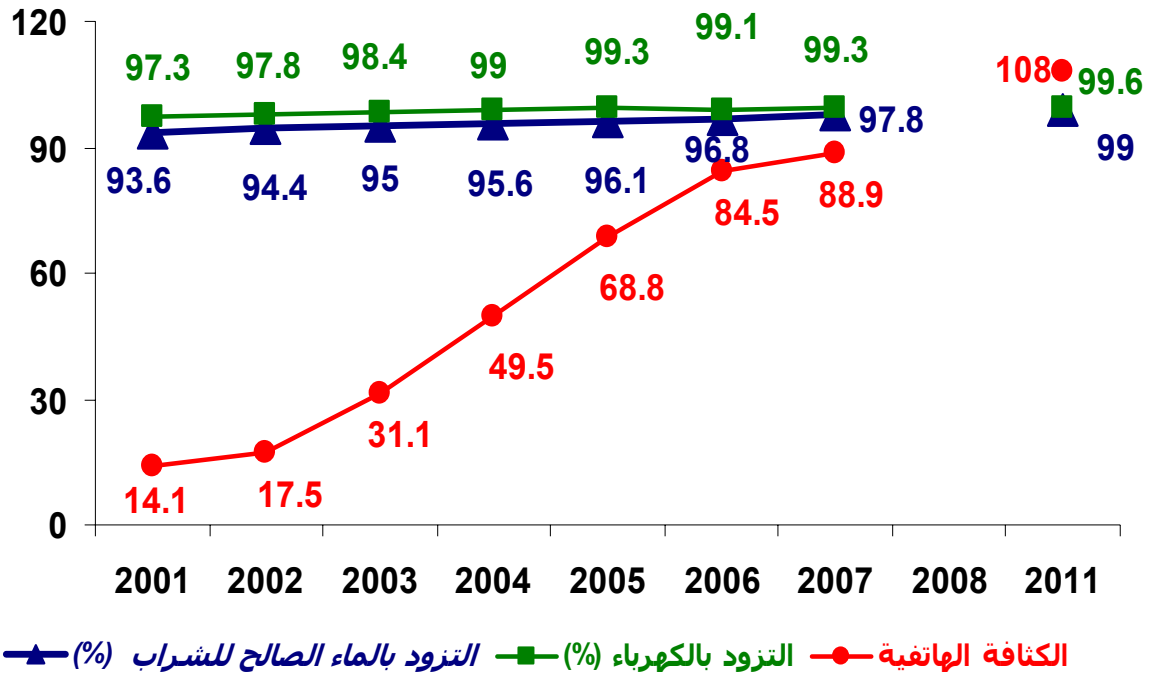

(28)

الجدول (28): جدول تألقي لتطور أهم المؤشرات التوجية للمجتمع التونسي

المؤشرات	2001	2002	2003	2004	2005	2006	2007	2008	2011 أهداف
المؤشرات الاجتماعية :									
معدل الدخل الفردي السنوي (بالدينار)	2987,8	3092,0	3299,7	3376,2	3737,3	4063,8	4349,9	4911,6	5752,8
التحويلات الاجتماعية نسبة إلى الناتج (%)	19,2	19,6	19,5	19,0	19,1	19,0	19,2	19,2	19,1
نسبة السكان مالكي المسكن	-	-	-	77,4	-	-	-	-	80,0
نسبة المساكن البدائية	-	-	-	-	0,8	-	-	0,5	-
نسبة الفقر (%)	6,2	-	-	-	3,8	-	-	-	-
الأمية (10 سنوات فما فوق) (%)	24,7	23,8	23,0	22,9	21,9	21,0	20,6	20,3	13,5
التغطية الإذاعية والتلفزيونية	-	-	-	-	99,8	-	-	99,8	-
نسبة إمتلاك الهواالي	-	-	-	54,4	-	-	-	75,4	-
نسبة الطبقة الوسطى في المجتمع	-	-	-	-	-	-	81,1	-	-
نسبة السكان في الوسط البلدي	77,6 (2000)	-	-	-	65,1	-	-	65,8	-
المؤشرات في مجال الصحة والتغذية الاجتماعية :									
العمر المتوقع للحياة (بالسنة)	72,9	73,0	73,1	73,4	73,5	73,6	74,2	74,8	76,5
عدد السكان للطبيب الواحد	-	-	-	-	1013	-	-	937	-
التغطية الاجتماعية (الضمان الاجتماعي) (%)	84,2	85,5	86,0	87,4	89,0	90,4	91,6	93,3	97,0
نسبة الولادات تحت المراقبة الطبية	-	-	-	-	-	-	-	94,6	-
نسبة عيادات مراقبة الحمل	-	-	-	-	-	-	-	96,0	-
المؤشرات الديمغرافية :									
مؤشر الخصوبة (معدل أطفال لكل امرأة)	2,05	2,0	2,06	2,02	2,04	2,01	1,92	1,96	1,62
النمو السكاني (%)	1,14	1,08	1,10	1,08	1,12	1,0	1,11	1,03	1,11

2011 أهداف	2008	2007	2006	2005	2004	2003	2002	2001	المؤشرات
99,0	97,9	97,8	96,8	96,1	95,6	95,0	94,4	93,6	مؤشرات التزود بالماء الصالح للشرب (%): المجموع الوسط الريفي
97	93,9	93,0	90,6	89,9	87,4	85,7	84,2	81,9	
99,6	99,5	99,3	99,1	99,0	99,0	98,4	97,8	97,3	مؤشرات التزود بالكهرباء (%): المجموع الوسط الريفي
99,5	99,0	99,0	98,5	98,3	97,3	95,7	93,9	92,4	
91,0	82,3	81,7	80,9	80,0	78,3	75,2	72,7	71,3	الربط بشبكة التطهير (%)
108,0	-	88,9	84,5	68,8	49,5	31,1	17,5	14,1	نسبة الكفاءة الواتقية (لكل 100 ساكن)
80,0	-	76,4	72,2	56,3	37,4	19,3	5,7	3,2	منها جوال
93,0	85,0	-	-	40,0	-	-	-	-	أهم المؤشرات البيئية : معالجة النفايات المنزلية بمصنّبات المراقبة المساحات الخضراء (أمتر مربع لكل ساكن)
16,0	15,37	-	-	12,3	-	-	-	-	

المراجع : - المخطط XI، جوية 2007 / - الميزان الاقتصادي، 2009  
- المسح الوطني حول السكان والتشغيل، 2007 / - التقرير السنوي حول التنمية لسنة 2008  
- المسح الوطني حول السكان والتشغيل، 2008

---

- 2000

-

:

( )

:

- 
- 
- 
- 
- 

)

( 2000 -

-





---

-1

2009

2000

2015

1.3

850

3.5

2.5

(

)

1-1

(1)

2008 /2007

-:

-

-

-

%35

%30

%12

(% 36.6)

(%34.3)

: (1)

(%31.8)

(% 35.9)

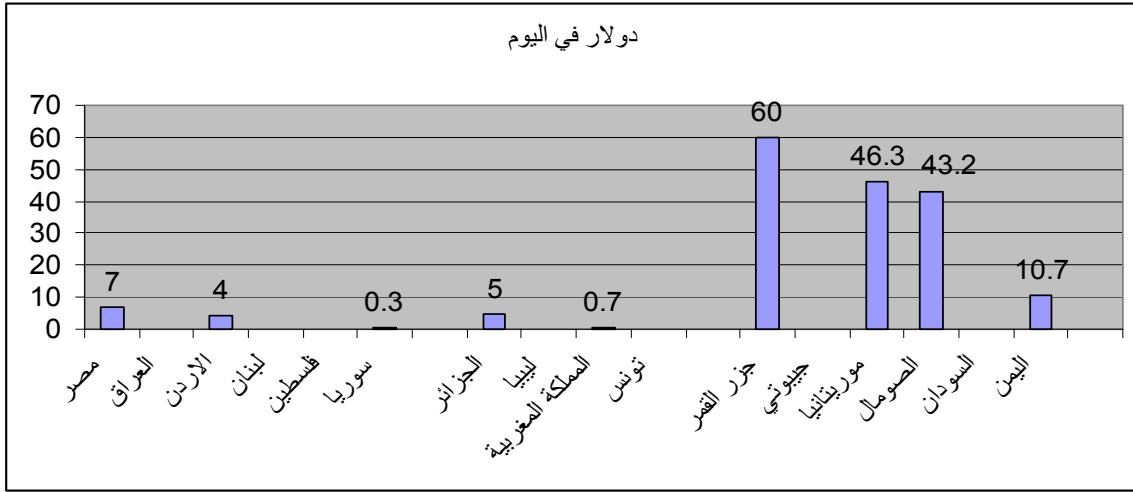

:

□

( )

□

□

2-1

2015

(1)

%6.3

2005

% 14.4

51 2020

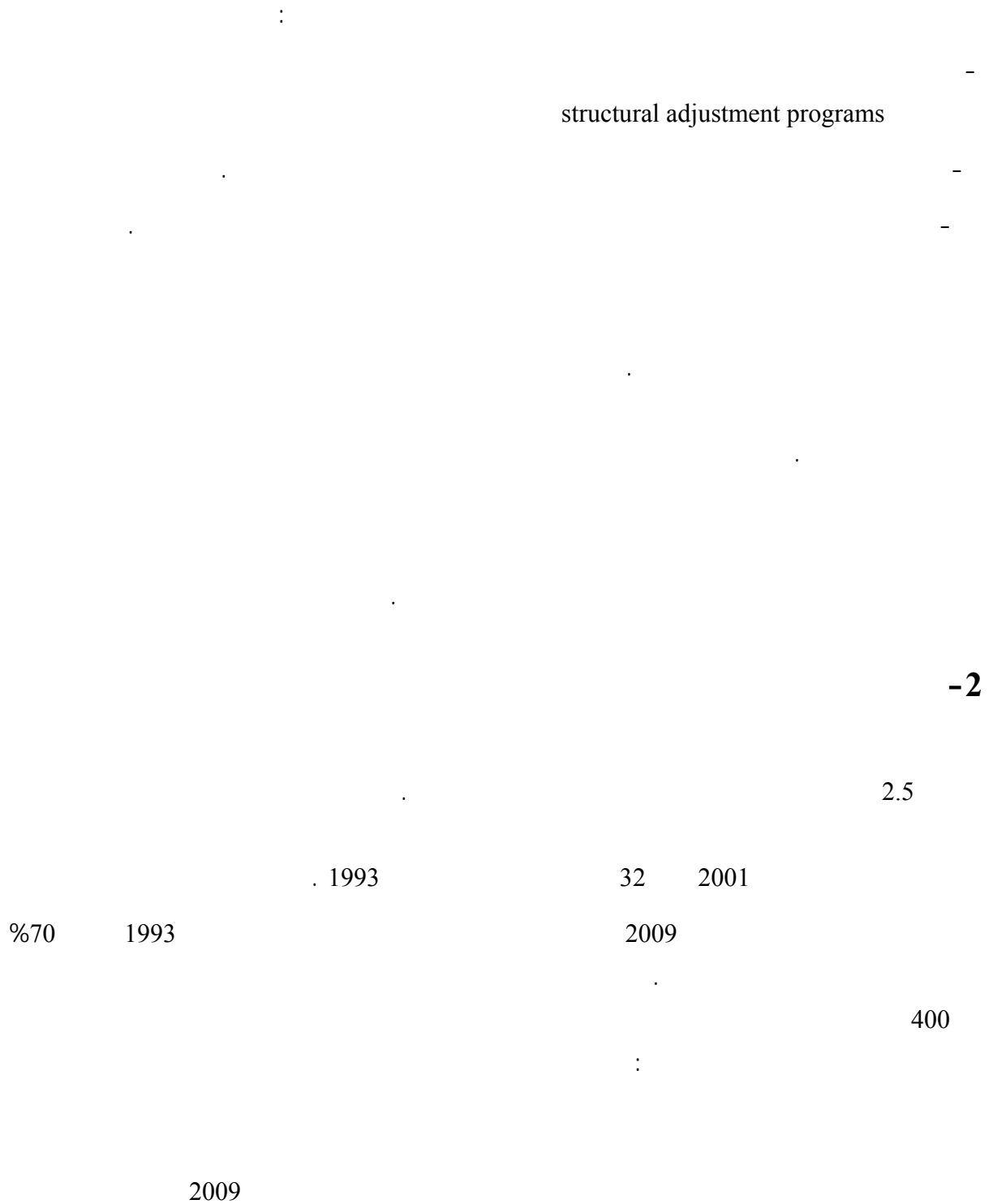

1993

. 1998

2000

2002 - 1994 (PRSP)

2004 . 2

(UNDP) (FAO)

%1 - -

(IMF) %25

(4) (3)

% 1.4

- (3)

2008	2007	2006	2005	2004	2003	2002	2001	2000	1999
1,350	1,283	1,235	1,177	1,117	1,116	1,027	0,991	0,963	0,931

( ) :

(4)

:(4)

2008	2007	1999	2000	2003	2004	2005	2006	
5.20	6.40	3.70	3.00	4.50	2.70	3.60	8.10	
47.3	47.0	47,1	47.0	47.0	47.0	47.0	46,9	( )
66.7	66.5		47.1	68.11	67.8	17.5	61.0	/
27,9	27.5	25,6	26,0	26.1	26.4	26.5	26.5	( )

. 2015

:

) . 2000

(

-3

1.7

labour force participation

2009

( 1993- 1983 )

%2.6

%29.3

33.6

1993 %6.6

15

( 1993 – 1983 ) % 48.5  
1996 % 45.5 1990 % 39.3  
%28 %18 (5)  
1996 – 1990 1996  
:(5)

18	59.7	44.3	37.2	39.3	1990
28.2	63.00	46.6	38.7	45.5	1996

2009

1996 – 1990 (5)

(%3.7 %4.2) %3.9

%4.9

%4 %7.8

%7.4

%6.3 %11.6

%6.8

%3

-

1973

1996 – 1973 (6) 1998

%5.5

1993 %11.1 1973

1996 – 1990 %15

1996-1990 %13 1996-1990

1996 %24.3 1990 %28

1996-1973 : (6)

	5.5	1973
	8.00	1983
	15.00	1990
	11.1	1993
	15.1	1996

1990

%10

3.3

%2.3

%12

(6)

1990-1970

.1990 %65 1970 %25

---

		400		1.6	
					-4
				1992	1992
					o
- 1970	(	)		(7)	
%6.4				1978 - 1970	. 2001
			.00.94	( Coefficient Variant )	
		1972			
				.1956	
				1980-1970	
				%27.9	
					% 6.6
		% 7.6			
%23.6					
					%14.3

---



%9.24 %14.3

%6.5

%15.8

%7.4

%2.6

1971

.%8

.(7)

1978- 1977

( )

:(7)

2001-1996	1990/1998 1995/1994	1999/1998 1982/1981	1981/1979	1978/1970	←
11.6 ( -79)	- 9.3 (1.58)	3.3 ( -2.64)	- 5.5 ( - 193 )	6.4 ( - 0.94 )	
35.8 (1.57)	118.7 (1.58)	39.5 (0.54)	27.0 (0.15)	14.3 (0.62)	

(7)

3.3 %2.1

%6

---

1995 – 1990  
 .(7)  
**2001 -1996**  
 1998  
 :  
 °  
 à 2001- 1995  
 . 1995 -1990  
 . 2001 – 1995  
 :  
 -  
 1990 – 1980 -  
 -  
 1990 1980 – 1970  
 2003 –  
 :  
 °

---

. 1992

o

-

-

:

\* \* \* \* \*

2020-2010		-1
		-
	:	
	1	-
1		-
	1	-
		-
	1	-
2020-2010		æ
		.
	" "	
	.2008/11/16-15	
	.2009/1/20-19	
		-
2020-2010		
	:	34 (6)
	:	
1		•
	1	•
		•

---

		-
	:	•
		•
	1 2003	•
		•
	1	•
1		•
	1	•
		•
	:	-
	1	•
	1	•
	1	•
		•
	1	•
		•
	:	-
1		•
	1	•
	1	•
	1	•
	1	•
	.2020	•
	:	-
	1 %	•
	1	•
1		•
		•

---

% 50

-

:

1

•

1

•

1

•

1

•

•

-2

æ

:

.2020

æ

:

: - 1 -	: 2009 1 1 -	.1 - - -
: - 1 -	: - 1 -	.2 - - -

1	1	
-	-	
1	1	
-	-	
1	1	
-	-	
1	1	
-	-	

2009 / 2020-2010 :

-3

2005 . 3.6 % 1990 4.3 %

11 1.25

17 %

51 - -

42 % 1.5 %

(29)

الجدول (29): معدل التشغيل الفقر على أساس تقديرات تعادل القوة الشرائية الجديدة باستخدام خطى الفقر  
1.25 دولار و 2 دولار للفرد يوم (2005)

	عدد الفقراء (بالملايين)				مؤشر نسبة الفقر (نسبة مئوية)							
	دولارات أمريكيان للفرد يوم		1.25 دولار أمريكي للفرد يوم		دولارات أمريكيان للفرد يوم		1.25 دولار أمريكي للفرد يوم					
2005	1999	1990	2005	1999	1990	2005	1999	1990				
747	1.101	1.277	339	634	893	39.6	61.5	80.0	18.0	35.5	56.0	شرق آسيا والمحيط الهادئ
44	71	49	20	27	18	9.3	15.0	10.6	4.1	5.6	3.9	أوروبا وآسيا الوسطى
93	109	89	43	54	44	16.9	21.2	20.4	7.9	10.5	10.0	أمريكا اللاتينية والبحر الكاريبي
<b>51</b>	<b>52</b>	<b>44</b>	<b>11</b>	<b>12</b>	<b>10</b>	<b>16.9</b>	<b>18.9</b>	<b>19.7</b>	<b>3.6</b>	<b>4.2</b>	<b>4.3</b>	الشرق الأوسط وشمال إفريقيا
1.091	1.030	924	595	589	577	73.9	77.3	82.7	40.4	44.1	51.7	جنوب إفريقيا
556	508	393	390	382	299	72.9	77.6	76.1	51.2	58.2	57.8	إفريقيا جنوب الصحراء
2.582	2.871	2.777	1.398	1.696	1.839	47.3	57.1	63.7	25.7	33.7	42.3	العالم

المصدر : BM : Note sur la pauvreté au Moyen-Orient et en Afrique du Nord-2008



---

(PNUD, 2009) ( )  
% 15.9 % 36.2 % 18.3 2005-2000

.2005

(30)

الجدول (30): بعض مؤشرات التنمية البشرية - 2005 (معدلات عالمية)

المناطق	متوسط الدخل الفردي بعملة الليرة الشراعية بالولايات المتحدة	متوسط مؤتمل الحياة (بعد السنوات)	متوسط نسبة المتعلمين (%)	متوسط السكان المتعلمين بين الترتيبات	متوسط السكان المتعلمين بمصادر المياه النظيفة (2004)	متوسط السكان المتعلمين بخدمات الصرف الصحي (2004)	متوسط نسبية السكان في المدن (%)
العالم	9543	68.1	78.6	76.0	83.0	59.0	48.6
منظمة التعاون والتنمية الاقتصادية	29197	78.3	-	100.0	99.0	96.0	75.6
البلدان العربية (تونس في التقرير)*	6716	67.5	70.3	غير متكور	86.0	71.0	55.1
	8371	*76.3	-	**99.0	96.0	85.0	55.1
	1998	49.6	60.3	26.0	55.0	370	34.9
إفريقيا ح ص	9527	68.6	99.0	غير متكور	94.0	-	63.2
أوروبا الوسطى والشرقية	8417	72.8	90.3	90.0	91.0	77.0	77.3
أمريكا اللاتينية	6604	71.7	90.7	غير متكور	79.0	50.0	42.8
شرق آسيا و الباسيفيك							

\* تجزئ الإحصاءة إلى أن مؤتمل الحياة بالنسبة لتونس في سنة 2005 حسب المصادر الوطنية يقتر بـ 73.5 سنة، والهدف هو الوصول به إلى 76.5 سنة في 2011.

\*\* مصدر وطني  
المصدر : BM : Rapport sur le développement humain-2007/2008

:

å

(la

.(A.Sen, 1985)

capacitation)

(% 3.6)

æ

% 15 3

:

1

1

( )



---

à

1

(Georges Gurvitch) (une totalité sociale) " "

<sup>1</sup> (jeux à somme nulle) "

( )

•

•

•

\* \* \* \* \*

	: (2005)	.1
	: (2000 1995 1990 1985 1980 1975)	.2
	:	.3
	: (2004)	.4
	: (2007)	.5
	: (2008)	.6
	: (2009 2008 2007)	.7
	: (2008)	.8
	: 2020-2010 : (2009)	.9

10. ATKINSON, Tony et coll, (1998), Pauvreté et exclusion, Insée, Paris.
11. Banque Mondiale (2008), Note sur la pauvreté au Moyen-orient et en Afrique du Nord.
12. Banque Mondiale (2009), Perspective Monde, Université de Sherbrooke.
13. FAURE Alain (1993), "L'intelligence des pauvres" in Démocratie et Pauvreté, PUF.
14. FRESSINET, Jacques (1998), L'indemnisation du chômage en Europe, IRES, Paris.
15. GESLIN, André (1998), Gens pauvres, pauvres gens dans la France du XIX<sup>s</sup>, Aubier, Paris.
16. LEWIS, Oscar (1965), la Vida, une famille portoricaine dans une culture de pauvreté, Gallimard, Paris.
17. Labbens, Jean (1969), Le Quart – Monde, Pierrelaye, Paris.
18. Labbens, Jean (1978), sociologie de la pauvreté, Gallimard, Paris.
19. PAUGMAN, Serge (2005), Les formes élémentaires de la pauvreté, PUF, Paris.
20. PNUD (2007/2008), Rapport Mondial sur le développement humain.
21. VERO, Josiane (2003), Justice sociale et pauvreté, 10<sup>ème</sup> journées d'études CEREQ, Caen, France.
22. SEN, Amartya (1985), Commodities and Capabilities, Amesterdam, North – Holland.

\* \* \* \* \*

---

:

---

:

-1

1-1

( Productivity )

( )

:

-

---

2-1





(1)

(2008-2005)

%						
	2008	2007	2006	2005		
2.20	5,849,000	5,723,000	5,600,000	5,470,000		1
1.72	4,689,000	4,453,000	4,229,000	4,106,427		2
1.68	1,123,000	1,039,297	960,425	888,824		3
1.08	10,318,793	10,208,900	10,107,100	10,014,100		4
1.60	34,351,000	33,810,000	33,278,000	32,786,000		5
3.00	899,000	833,000	779,000	721,000		6
2.40	24,286,670	23,980,834	23,678,849	23,118,994		7
2.63	37,448,214	36,666,857	35,470,000	35,397,000		8
2.60	19,644,000	19,172,000	18,717,000	18,269,000		9
1.00	10,307,964	10,220,857	10,183,000	10,082,000		10
3.00	30,582,000	29,683,000	28,810,000	27,963,000		11
1.50	2,867,428	2,743,000	2,577,000	2,509,000		12
3.30	3,891,622	3,761,646	3,952,354	3,825,149		13
1.18	1,448,446	1,226,210	1,041,734	888,452		14
1.32	3,414,820	3,228,235	3,051,845	2,866,888		15
1.07	3,911,857	3,872,571	3,835,000	3,780,000		16
3.10	6,437,191	6,322,191	5,673,031	6,097,000	(1)	17
1.94	74,311,000	73,436,000	72,011,000	70,653,000		18
1.50	31,769,000	30,844,000	30,506,000	30,172,000		19
2.90	3,393,643	3,281,286	3,128,000	3,054,000		20
3.00	22,198,000	21,539,000	20,901,000	20,283,000		21
2.08	333,141,648	326,044,884	319,081,882	312,944,834		

. ( 2010 ) -:

2006

(1) -:

(2)

( 15 )

( )

2007

82.20	91.70	80.30	14.40	5.50	16.10	3.40	2.80	3.60	2007		1
84.85	86.00	55.00	10.65	14.00	36.00	4.50	-	9.00	2006		2
84.67	87.87	84.39	14.53	12.13	15.61	0.80	-	-	2008		3
67.13	62.61	68.81	17.12	23.43	14.77	15.75	13.96	16.42	2007		4
70.90	65.75	72.0.	11.50	22.18	9.19	17.60	12.07	18.80	2007		5
86.53	88.00	78.00	11.12	1.00	11.00	2.35	11.00	12.00	2007		6
86.53	99.00	93.77	9.04	0.65	10.53	4.43	0.35	5.17	2007		7
42.30	34.06	45.95	6.62	2.49	7.74	51.08	63.45	46.31	2007		8
66.68	66.93	66.65	14.18	6.77	15.26	19.14	26.30	18.09	2007		9
63.06	59.85	57.90	12.14	2.30	8.60	24.80	37.85	33.50	2007		10
64.80	66.95	64.10	7.80	4.60	11.25	27.40	28.45	24.65	2008		11
84.33	97.50	81.23	9.50	1.30	11.52	6.17	1.20	7.25	2007		12
77.90	54.50	82.91	9.90	9.50	9.87	12.20	36.00	7.22	2007	/	13
82.68	96.37	81.12	14.65	3.63	16.21	2.67	-	2.67	2007		14
91.74	97.87	89.70	6.45	1.69	8.06	1.81	0.44	2.24	2006		15
77.80	76.40	78.12	14.00	14.85	13.73	8.20	8.75	8.15	2007		16
76.20	94.22	79.68	19.50	1.70	9.80	8.84	4.08	10.52	2006		17
48.70	55.00	49.00	21.10	6.00	23.00	30.20	39.00	28.00	2008		18
48.00	21.00	40.00	19.60	19.00	21.00	32.40	57.00	39.00	2007		19
64.86	85.25	57.61	10.62	4.92	12.67	24.52	9.80	29.87	2007		20
69.03	72.38	68.63	5.79	5.02	5.72	25.28	22.60	25.65	2007		21
72.42	74.25	66.80	12.39	7.74	13.70	15.41	17.86	16.57	%		

( 2010

).

- :

---

					-
	2007-1995	%3.3			
%7		%6	%9		(.2)
	4				
					-
		%64	2007		
	14.8		29.9		5
	9.8		13.2	13.9	
			(%59.4)		■
		%15.4		(%25.2)	
	2007	%25.2	1995	%33.6	
2007	%28.1				■
					■
					■
					-
%13	2000	%14.3			
			2007		
			%5.7		
					(.3)

---

(3)

(2007 )

%	%		15			
23.80	2.20	5,849,000	1,342,815	2008		1
61.89	1.72	4,453,000	2,756,000	2007		2
72.41	1.68	1,039,297	583,618	2008		3
34.01	1.08	10,208,900	3,593,200	2007		4
29.48	1.60	33,810,000	9,968,000	2007		5
34.51	3.00	833,000	336,109	2007		6
34.29	2.40	23,980,834	8,299,658	2007		7
32.79	2.63	36,666,857	12,022,000	2007		8
28.10	2.60	19,172,000	5,400,777	2007		9
34.00	1.00	10,220,857	4,464,000	2007		10
31.00	3.00	29,683,000	9,201,700	2007		11
37.85	1.50	2,867,428	1,085,321	2008		12
22.57	3.30	2,867	849,000	2007		13
67.51	1.18	1,226,210	827,802	2007		14
58.32	1.32	3,228,235	1,879,700	2007		15
32.22	1.07	3,872,571	1,247,000	2007		16
26.01	3.10	6,322,191	1,644,600	2007		17
32.08	1.94	74,311,000	24,189,000	2008		18
35.02	1.50	31,769,000	11,229,000	2008		19
31.34	2.90	3,281,286	1,230,964	2007		20
21.50	3.00	22,198,000	4,772,570	2008		21

( 2010

) :

107

2007

325

- :

2009

-3

1-3

1899

2007

%15.1

%26.2

2008

.(1)

2000

الشكل (1): معدل نمو الناتج المحلي الإجمالي لمجموعة الدول العربية للفترة 2008-2000

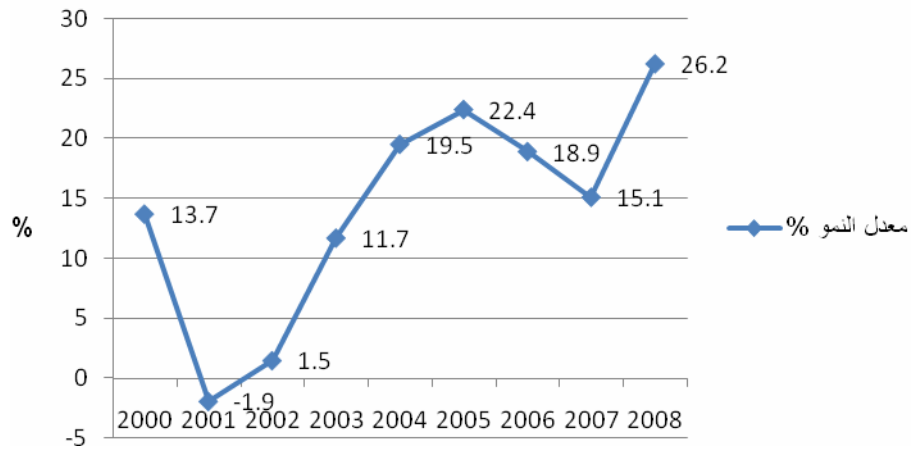

2009

%6

2007

%5.2

.(2)

2008

الشكل (2): معدلات نمو الناتج المحلي الإجمالي بالأسعار الثابتة للدول العربية\*

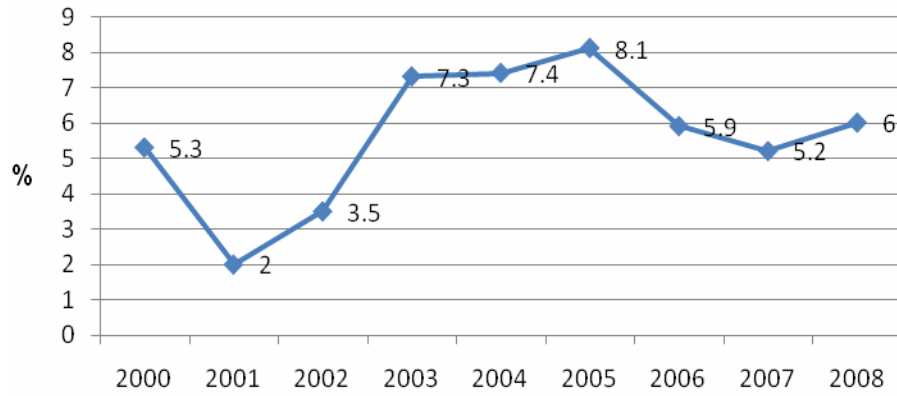

\*بسر صرف ثابت لعام 2005، وبالأسعار المحلية الثابتة لسنة أساس 2005=100

2009

2008

%43.4

%.5.4

%8.9

%36

2008 %56

.2007 %24.4

2008 %25.6

%142.8

2007

%138.3

.2008

2008

(4).

:(4)

2008 2007 (%)

2008	2007	2008	2007	2008	2007	
24.9	16.2	24.9	16.2	5.6	6.5	
27.4	16.8	27.4	16.8	7.4	5.2	
31.9	16.4	31.9	16.4	6.1	8.1	
14.7	14.5	10.3	10.2	4.6	6.3	
27.0	14.4	18.1	9.2	3.0	3.0	
15.8	10.2	15.8	10.2	5.8	5.1	
22.1	7.8	22.1	7.8	4.4	3.3	
8.0	24.4	12.0	15.5	7.8	9.7	
28.9	22.1	21.0	18.9	5.2	6.3	
52.3	32.2	46.0	13.3	10.9	5.9	
44.0	13.1	44.0	13.1	6.2	7.7	
44.0	25.1	44.0	25.1	16.4	15.3	
29.3	12.8	22.1	10.6	6.3	4.4	
18.3	11.6	18.3	11.6	6.3	4.0	
20.2	15.6	18.3	11.2	6.2	6.0	
24.8	21.4	20.4	20.6	7.2	7.1	
14.1	14.4	7.8	6.6	5.4	2.7	
28.2	4.4	25.3	0.6	5.1	1.0	
21.0	13.5	21.5	14.6	3.9	3.3	

. 2009

2-3

755 4

%23.2

2008

5.858

2007

.(5)

2007

%12.3



(5):

( ) 2008-2000

%	2008	2007	2006	2005	2004	2003	2002	2001	2000	
2008-2007										
21.9	70651	57946	54534	47818	41976	32777	28393	27024	28784	
20.0	52574	43815	39816	33690	28379	24412	21987	21758	23365	
25.0	43046	34431	33273	28182	22472	19271	16136	15562	16927	
22.0	21668	17754	16512	15140	13635	14127	12635	12169	12582	
37.7	20898	15180	14282	12318	10213	9202	7899	7829	8097	
19.3	18898	15835	15041	13640	11095	9743	8772	8723	9203	
16.4	10520	9038	8071	6848	5206	4227	3641	5141	6130	
17.5	7466	6353	5729	5617	5635	5225	4902	4493	4430	
23.2	5858	4755	4234	3647	3056	2615	2393	2414	2518	
24.8	4916	3939	3503	3133	2637	2131	1810	1772	1801	
13.5	3959	3487	3076	2901	2844	2539	2366	2073	2032	
22.2	3630	2971	2614	2300	2130	1949	1880	1803	1742	
47.9	3611	2442	1904	1192	910	403	682	713	871	
25.8	2677	2128	1785	1555	1392	1236	1207	1210	1159	
12.4	2632	2342	2079	1916	1862	1655	1366	1295	1288	
22.4	2192	1791	1505	1279	1276	1205	1291	1506	1573	
5.3	1599	1519	1253	994	771	635	553	492	432	
16.8	1181	1011	923	817	680	604	569	544	526	
12.3	1131	1007	942	895	867	839	820	818	813	
25.2	1128	901	884	623	513	453	413	412	405	

2009

3-3



2008

1899	2007	1505	
. 2007	%15.1	%26.2	2008
2007			
%37.4		% 6.1	%39.8
			%9.4

-4

70.8				
	%5		%36%	2007
. 2007			%30.4	( )
	%12			
	.2007	%1.9		
	%25.2		25	
	.2000	%31.8		2007
	%75.2			
%42.1		%44.1		% 53
%7		%13	%13.6	%27
		(7)		%30

: (7)

( )

% 2007-2006	2007	2006	
3.6	25,135	24,262	
3.8-	75	78	
3.8-	177	184	
0.0	9	9	
3.4-	566	586	
37.9	2,220	1,610	
0.7	278	276	
2.0	618	606	
0.6	6,000	5,963	
0.6-	946	952	
3.0	1,343	1,304	
4.8	281	268	
18.8	19	16	
0.0	34	34	
4.9-	35	37	
2.3-	87	89	
2.3	6,231	6,909	
0.1-	4,626	4,631	
0.0	330	330	
5.0	1,260	1,200	

2009

(8) 2008 103.4  
 ) 2007 %14.2  
 2008 %5.4(  
 %7.8 %13.1 %20.4 2008 %29.3  
 2008

319 2008 %11.6

(8)  
 735 441 2008  
 384 146  
 126

:(8)

	2008 ( )	% 2008-2007	2008-2000 %	( ) 2008	
5.4	319	14.2	7.2	103,385	
2.5	93	25.0	15.5	542	
1.4	735	34.1	4.5	3,504	
0.3	64	7.2	2.2	72	
9.7	384	7.5	6.5	3,963	
6.6	323	10.8	11.8	11,197	
3.3	37	13.8	8.2	32	
2.3	441	2.2	2.0	10,947	
29.3	469	9.5	17.9	17,922	
20.4	547	27.9	11.0	10,741	
4.1	146	3.3	17.8	4,477	
1.0	213	16.4	5.3	610	
0.1	51	7.2	1.3	74	
0.2	78	9.4	9.0	268	
7.8	583	18.3	7.4	2,313	
2.1	223	7.8	6.6-	1,630	
12.6	277	17.3	3.6	20,520	
13.1	344	22.5	10.8	11,202	
11.1	126	13.4	4.8	402	
10.4	122	19.7	11.0	2,972	

2009

---

13.6					
50.6		2006		11.8	2007
				42.7	
	.2006	30	2007		37
	2006	23.8			
		.2007	%29.3		2007
%57.3	%48	%54.9			
			.2007-2006		%46.8

:

- 
- 
- 
- 
- 
- 

:

---

•  
•  
•

**-5**

		993.3	2008				
			.%35.1		2007		735.3
		.2007	%48.9		%52.3		2008
2008	%43.4				%38.6		
		2008	%20.2				
	.(9)	2008	8.9	2003			





:(10)

(2008 )

(%)	(%)	
52.3	993,329.9	
23.6	5,018.0	
50.8	127,271.3	
39.8	9,697.2	
27.0	11,044.5	
49.3	83,994.7	
65.4	306,790.0	
23.3	14,245.0	
32.8	17,247.9	
67.7	74,769.5	
61.7	36,978.2	
68.5	70,087.6	
65.0	96,367.0	
9.1	2,691.4	
79.3	60,828.8	
31.3	50,833.0	
15.7	13,472.8	
37.3	1,349.5	
37.0	10,617.5	

2009

%15.4

) 2006 2004

(11)

.(

(11):

2006	2005	2004	
32,341	27,049	20,129	
19,005	17,092	15,137	
302,490	245,664	187,093	
69,899	56,518	42,125	
5,885	5,423	5,423	
26,854	22,604	16,672	
780	816	815	
302,599	262,140	188,793	
7,394	5,065	3,557	
7,410	6,362	5,093	
-	-	-	
21,599	17,668	14,062	
233,797	199,397	144,526	
-	25,329	24,757	
846,520	709,397	535,300	
207,177	171,053	112,305	
4,868	4,673	4,682	
95,347	77,856	55,658	
5,336	4,218	3,809	
4,364	3,952	3,662	
14,936	5,673	5,346	
16,000	13,866	10,051	

%15.4

:

---

2007 %48.9

.2008 %52.3

2008 %43.47 2007 %39.5  
%8.9 2007 %9.3

. 2008

12

:

- 
- 
- 
- 
-

2007	735.3	993.3	2008
			%35.1
	2007	% 48.9	2008
2008	%43.4	2007	%39.5

(4)

2007

)

(.....

(12) .2008 %36

:(12)

(2008-2007)

2008	2007	2008	2007	
320,857	275,602	361,025	298,091	
6,024	5,330	5,773	4,546	
42,291	34,407	57,061	45,370	
4,744	4,219	8,324	5,339	
7,661	6,755	12,104	10,460	
20,211	13,575	31,596	25,291	
250	212	524	460	
78,947	76,190	46,521	42,215	
6,767	6,165	17,352	16,375	
6,063	5,000	22,566	18,034	
25,199	17,907	18,609	11,736	
8,666	7,846	10,013	7,412	
15,048	11,223	9,694	8,288	
22,460	19,867	24,868	23,138	
10,326	8,731	11,282	9,539	
9,770	9,099	7,190	6,093	
23,704	20,446	51,047	40,793	
26,699	23,419	17,881	15,852	
775	678	495	420	
5,294	4,532	8,126	6,730	

2009

	2007	2006
		%59.4
	%86.7	%83.7
		%75 %70.8
7,000		(2)
		<b>-7</b>
		<b>1-7</b>
	2008/2007	%2.42
3		
		<b>2-7</b>
%3.6	1990	%4.3
		2005
		1.25
		11
.%17		
51	-	-

---

.%1.5 %42

3-7

%14

:

( )

15

24

. %14.4

%26.5

%50

(3).

%30

2020- 2010

%50

)

(2010 18-16

( )

- 
- 
- 
- 
-



---

Governments

Capacity

- 
- \*
- \*
- \*
- \*
- \*
- \*
- 
- \*
- \*
- \*
- \*
- \*
- \*
- \*
- \*
- \*
- \*
- 
- 

( )  
:

---

( )

:

\*

\*

\*

\*

)

(

•

( )

:

\*

\*

( )

\*

/

•



●

:

\*

\*

\*

●

)

(

●

\*

\*

\*

.( )

●



---

-8

1-8

:

2020

-

:

•

•

•

%10

•

\_\_\_\_\_ ( 2009/1/20 – 19 )

\_\_\_\_\_ (2020 – 2010 )

2-8

\_\_\_\_\_

:

-

2009

-





---

( ..... - )

\* \* \* \* \*

---

					■
	-				.1
		2008	/	16 -15	-
		2007 -			.2
				2009 -	.3
				2008/2007	.4
	2009	/	20 -		.5
	2009	/			.6
		2007			.7
				. 2010	.8
					■

9. [www.mawsoah.net](http://www.mawsoah.net) -

10. (www.ILO.org) ILO

11. [www.worldbank.org](http://www.worldbank.org) - -

12. [www.escwa.un.org/arabic](http://www.escwa.un.org/arabic)

13. Nabli, M. et al. Job Creation in a High Growth Environment: the MENA Region, Middle East and North Africa Working Paper Series No. 49, the World Bank (2007).

\* \* \* \* \*



---

2008

:

---

---

:

2009.

2008

:

:

■

•

1

1

•

1

•

1

•

•

1

:

■

)

•

1(

1

•

---

---

•

■

•

•

•

•

•

•

(1)

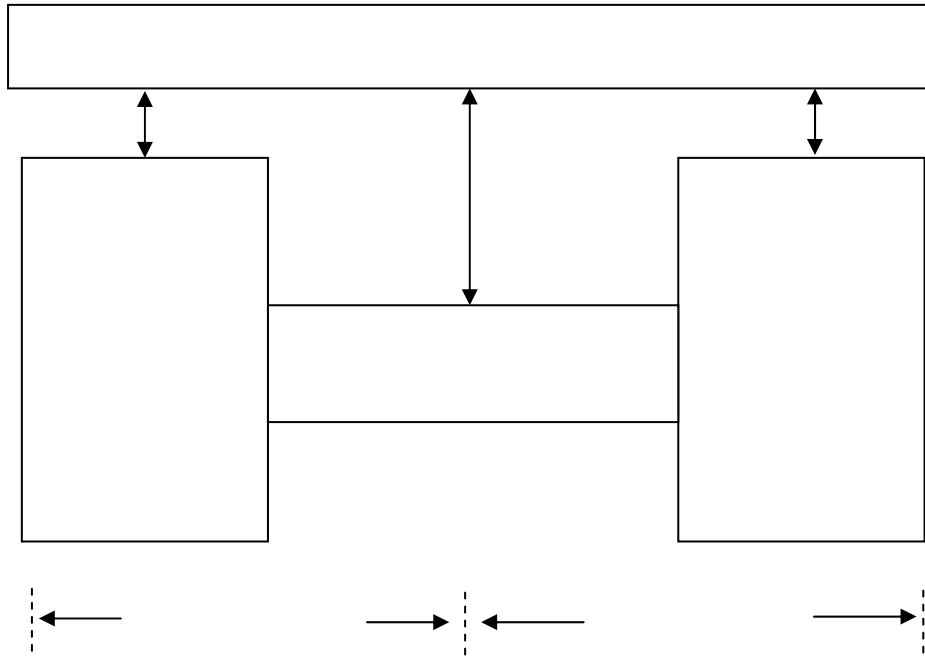

:(1)

-1

:

1

1

1

:

---

1

1

1

1

1

: -2

” ”

---

( )

( )

æ

:

(2)

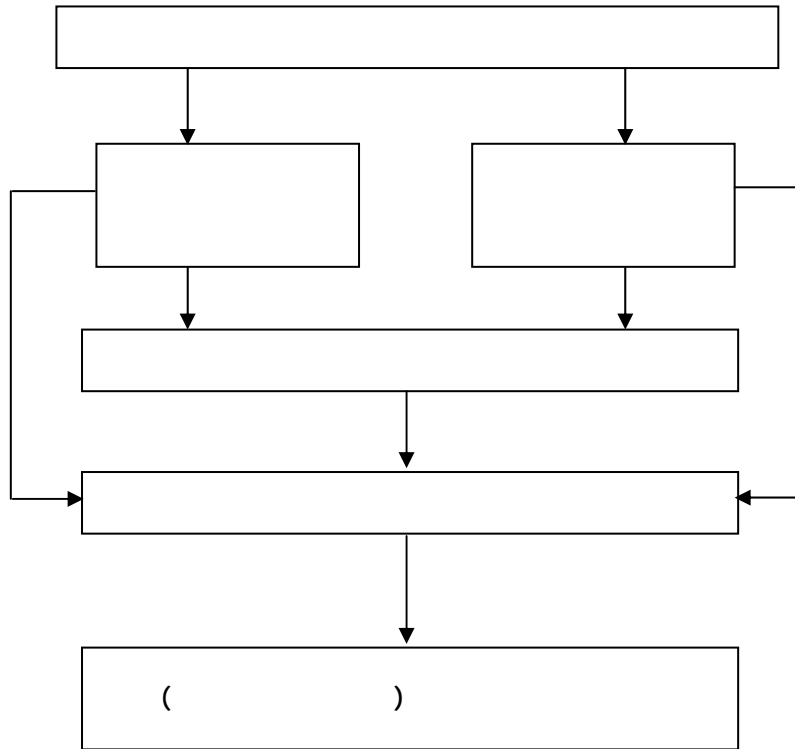

:(2)

:

:

---

:

( )

( )

:

( ) :

( )

- 
- :
- :
- (2008) •  
International Standard Classification of Occupations (ISCO88&09)
  - International Standard Industrial Classification (ISIC)
  - International Standard Classification of Education (ISCED 97)

**-3**

â

â

:



---

-4 :

2009



( )

:

( )

/ :

( )

( )

:( )

:

---

( )

( )

(Major Group)

( )

---

(Sub-major group)

:

(Minor group)

:

(Unit group)

:

(1)

: (1)

	( )	( )	( )	( )
-	40	10	5	-1
1	73	25	6	-2
2	71	22	6	-3
3,4,5	21	8	4	-4
3,4,5	34	11	4	-5
3,4,5	15	5	2	-6
3,4,5	80	18	4	-7
3,4,5	66	19	3	-8
5	27	11	3	-9
-	3	3	3	-0
-	<b>430</b>	<b>142</b>	<b>40</b>	

---

1

:

(1) : \*

(2) :( ) \*

(3) : \*

(4) : \*

(5) : \*

**-5**

.1989

(2008).

â

:

1

1

1

---

1

1

2008

-6

( )

---

International Standard Classification of Occupations (ISCO) •

International Standard Classification of Education (ISCED) •

â



:  
(5 : )

.( )

.(4 3 : )

.(2 : )  
( )

:( )

(3)

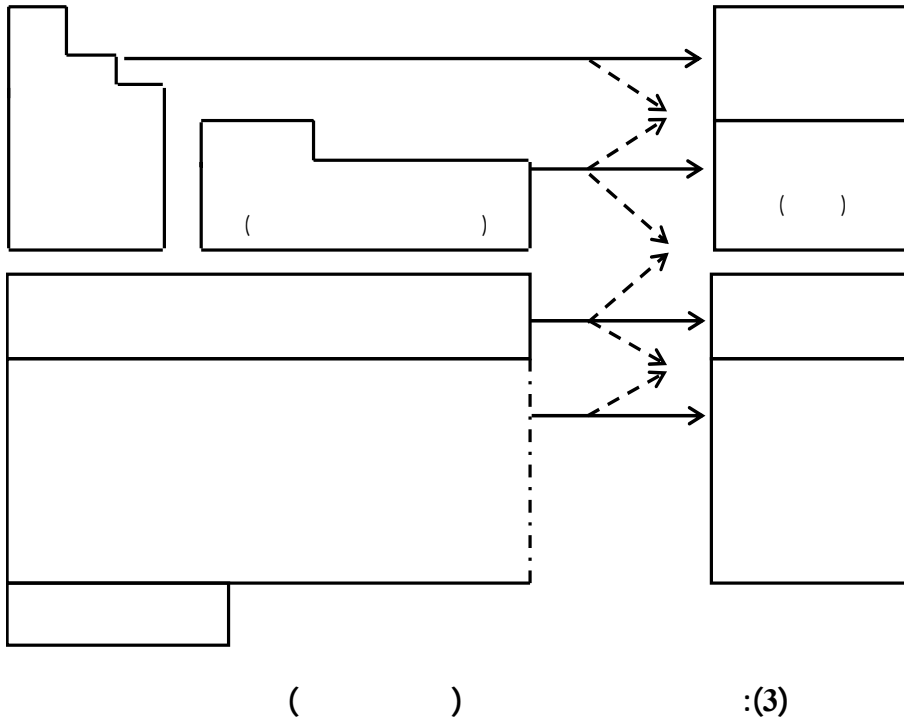

( )

( )

(4 )

(5 )

(6 )

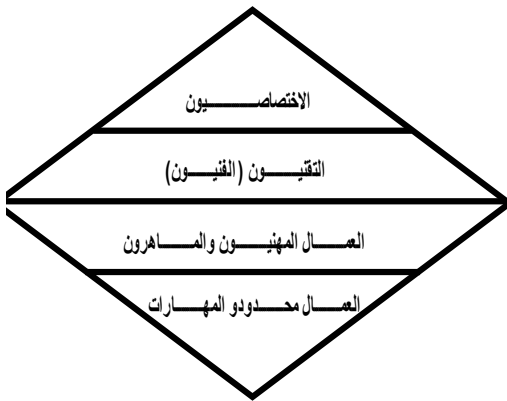

:(5)

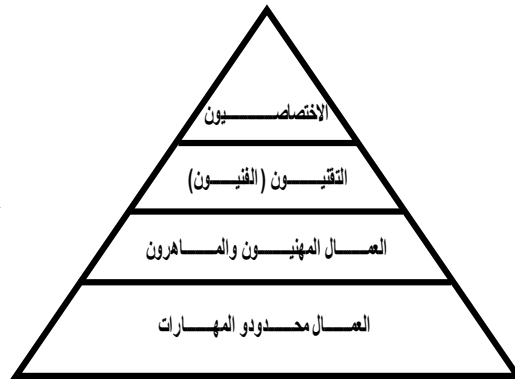

:(4)

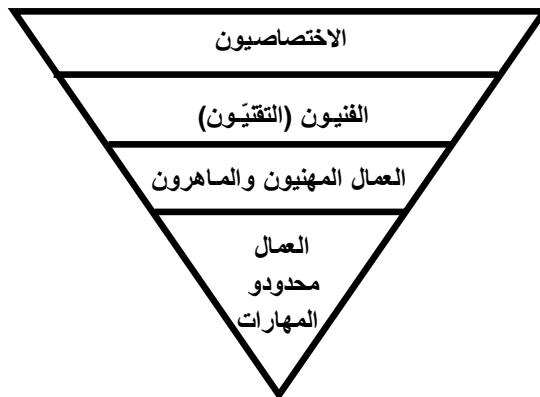

:(6)

---

(1356)

2007

2003

" "

---

â

:

-7

:

1

1

1

1

1

1

1

---

■

1

1

■

■

1

**-8**

.2008

â

( International Standard Classification of Education-ISCED-)

.1997

---

-9

1 :

(2008)

.2009

:

أ-

ب-

(2008)

د-

و-

---

ز-

ح-

( ) ( )

\* \* \* \* \*

	( )	.1
	.2003 ( )	
	( )	.2
	.2004 ( )	
		.3
		.1998 ( )
.1990	( )	.4
	( )	.5
		.2008
:	( )	.6
	.1993	
		.7
		.2004
)	( )	.8
	.2005 (	
:		.9
	.2008	

10. Human Resources Development Canada, National Occupational classification: Index of Titles, Canada Communication Group, Ottawa (Canada), 1994.
11. Center for Civic Education, National Standards for Civics and Government, Center for Civic Education, Calabasas (California), 1994.
12. International Labour Organisation, (ILO), International Standard Classification of Occupations (ISCO), ILO, 1988.
13. UNESCO, International Standard Classification of Education (ISCED), UNESCO, 1997.



- 
14. International Labour Organisation (ILO), Global Employment Trends for Youth, ILO, Geneva, 2007.
15. Fuente, A. & Ciccone, A., Human Capital in a Globalised and Knowledge-Based Economy, European Communities, Luxembourg, 2003.

( ) .16

- [www.planning.gov.qa](http://www.planning.gov.qa) :
- [www.hrdf.org.sa](http://www.hrdf.org.sa) :
- [www.almanar.jo](http://www.almanar.jo) :
- [www.alolabor.org](http://www.alolabor.org) :
- [www.ianmia.ae](http://www.ianmia.ae) :
- [www.manpower.gov.om](http://www.manpower.gov.om) :

\* \* \* \* \*



---

:

---

:

( )

:

( )

-

-

-

---

-1

1-1

Concept -

Explicit  
Learning Outcomes

Implicit  
Level Descriptors

ISCED 97

ASCO 08

ISCO 08

1

Subsystems

1

1

1

1

Mobility

1

( )

1

---

<sup>1</sup>Regulated Occupations

1

1

:

)

(

---

	/	▪
		▪
		▪
		▪
		▪
( )		▪
	/	▪
		■
		▪
Status		▪
	/	▪
	Employability	▪
		▪
		2-1
	:	▪
		■
(Cedefop)		
	2005	2004
	/	

---

2010

32

2005

/

.2006 /

.( ) 8 ( ) 1 8

: Descriptors

Factual ( )

: ●

Cognitive /

: ●

Manual

Autonomy :

: ●

.Responsibility

(1)

( ) :(1)

Descriptors			
			1
			2
	/		3
			4

			5
			6
/	/		7
	/		8

**Hierarchy** ■

: ( )

**Educational Hierarchy** ●



."

" : 2

" :6

."

Bologna

( 8,7,6,5 )

( ) Short cycle

Cycles

(2)

ISCED 97

: (2)

ISCED 97

ISCED 97		
6		8
	5	7
		6
		5
4		4
3		3
2		2
1		1

Occupational Hierarchy



ISCO 08

.ISCED 97

(3)

ISCED 97

ISCO 08

(3) :

ISCED 97			ISCO 08
6		8	4
	5	7	
		6	
		5	3
4		4	_____
3		3	2
2		2	1
1		1	

■  
: / ( )

:

/

10 .2003



---

			6	•
			6	
		6		
			7	•
	3		7	
	Ordinary Bachelor Degree	7		
	Honors Bachelor Degree			
			8	•
4-3				
			8	
			9	•
			10	•
				■
			(4)	

: (4)

	/		
3	2	1	
	6	5	4
	5	4	3
8	7	6	
		10	9
8	7	6	
		10	9
9	8	7	
			10

-

:

5

12

( )

( 5)

: (5)

		/	
			12
5			11
	/		10
	/		9
4	(HND)		8
			7
3			6
2		2	5
1		1	4
		3	3
		2	2
		Access 1	1

( )

(1)

:(1)

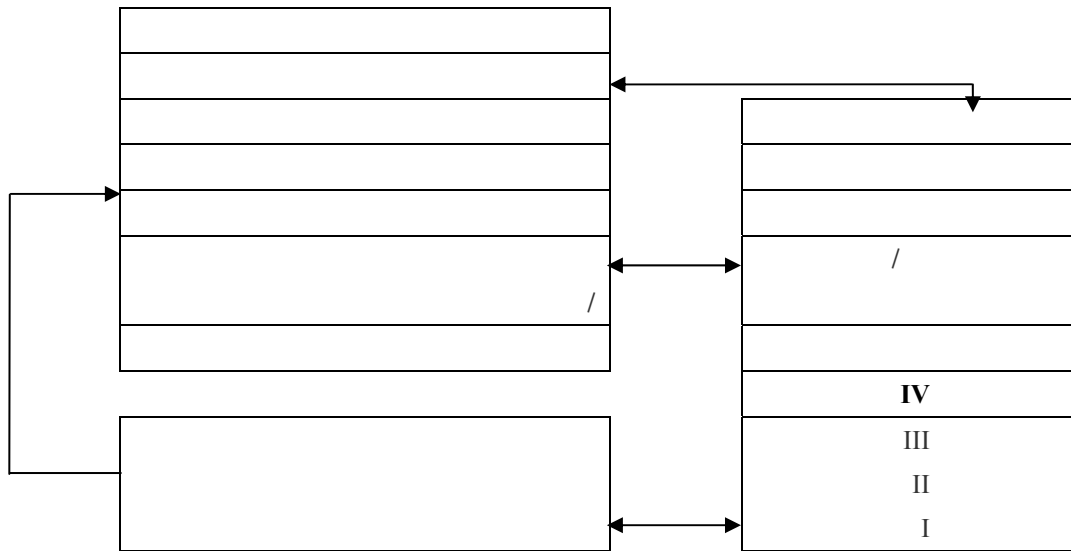

IV III II I

(6)

IV III II I

: (6)

IV	III	II	I



- 
- 
- 

( )

3.1

.

( )

7 .(ETF)

( )

2130 2009.

Responsibility      Autonomy      Complexity      : ( )  
Adaptability

Adaptability

- : •
- : •
- : •
- : •

(7)

/ (7)

•	•	•	•	•	•	•	•
	•			•		•	
	•					/	
•	•	•	•	/	•	•	•
	•		•		•		









ISCED 97

1

1 2008

)

1

(

1

)

1(

1

97

(2)

.97

97

:(2)

97				
6				
5				
			/	
			/	
4				
3				
2			/	
1			/	

2008

(3)

ISCED 97

:(3)

ISCED 97

2008

9
8
7
6
5
/ 4
)
(
3
2
1

6
5
/ 5
4
3
2
1

/

.2

1.2

Criterion reference

---

Job performance standards

Training performance standards

( )

( )

**Up skilling**

Skill levels

/

---

Skill specialization

:

Skill level

-

-

/

Methodologies

:

**Occupational Analysis**

:

:

:

:

Roles

Functions

:

Tasks

:

Performance Criteria

:

Psychomotor ( )

Cognitive

Affective ( )

---

## Functional Analysis

▪

:

Key purpose ( )

:

•

Key areas

:

•

Competence units

Units

:

•

Competence elements

:

•

Steps of work

:

•

## DACUM

▪

Developing A Curriculum

:

DACUM Workshop

:

•

Facilitator

Key

Areas



---

•

2.2

-

/

/

Dual system

Occupations

( )

Narrow jobs

( )

-

-

( )

Modular Training Approach

Modular Units

1999 27

)

.(

( )

( )

.Function

:

:

:

	1
	2
	3
Carburator .	4
	5
( )	6
( )	7
	8

	9
	10
	11
	12
	13
	14
	15
	16
	17
	18
	19
	20
	21
	22

( )

:

				/	
	•	•	•		-1
	•	•	•		-2
	•	•	•		-3
	•	•	•	Carburetor	-4
	•	•	•		-5
•	•	•	•	( )	-6
•		•	•	( )	-7
•		•	•		-8
•		•	•		-9
•		•	•		-10
		•	•		-11

		•	•		-12
		•	•		-13
		•	•		-14
		•	•		-15
	•	•	•		-16
		•	•		-17
			•		-18
		•	•		-19
		•	•		-20
			•		-21
			•		-22

:

3 2 1) (	) (						
1			1-1		1		1
1			2-1				
1			1-2		2		
1			2-2				
1			3-2				
1	+		4-2				
1	+		5-2				

1		( )	6-2				
1			1-3		3		
1			2-3				
1			3-3				
1	+		4-3				
1	+		5-3				
1		( )	1-4		4		
1		( )	2-4				
1	+		3-4				
1			4-4				
1			1-5		5		
1			2-5				
1		( )	3-5				
1			4-5				
1			5-5				

-3

-2

-1 :

\*



---

( )

( )

( )

:

3

(4)

(4):

5112075			
A			
A1			

•	• • • •

• • • • • • •		• • •

المتطلب للحصول على المؤهل	المسمى المهني	المستوى
الشهادة الجامعية أو المؤهل التخصصي	اختصاصي	المستوى الخامس
الشهادة الثانوية والتدريب أو الخبرة	فني متقدم ( تقني )	المستوى الرابع
الشهادة المتوسطة والتدريب أو الخبرة	فني	المستوى الثالث
تدريب مهني أو مهارة مكتسبة	ماهر	المستوى الثاني
القدرة على القراءة والكتابة	محدود المهارات	المستوى الأول



---

10

270

(AFBA)

(SQA)

(IB)

(CP)

:

\*

.Demand side

Occupational profile

Demand specifications /

\*

/

/

Assessment Specifications

Training Specifications

▪

:

:

▪

:

:

▪

:

:

▪

MT 3.3 :

MT 3.3.3:

: ( )

•	• • •	•	• •	-1
•	• •	•	• • • •	-2
•	• • •	•	• •	-3
•	• •	•	• •	-4
•	• • •	•	• • •	-5

	( )
	/ /
	/
	/

▪

105

235

4.2

Purpose

-

: /

-

.( )

•

•

-

.( )

-

-

-

---

2008

Regulated Occupations

.( )

Labour extensive

)

(

---

( )  
(2008 )

Occupational Profile

Model

( )

\* \* \* \* \*

			152	57		-1
						-2
					2001	
						-3
2006	/	"	...	"		-4
					( )	-5

- 6- National qualifications Authority of Ireland, The national framework of qualifications
- 7- Raffé,D. Qualifications frameworks in Europe: Learning across boundaries, Report of the Glasgow Conference 22-23 September 2005.
- 8- CEDEFOP, European journal of vocational training. NO 42/43
- 9- Young,M, National Qualification frameworks: their feasibility and effective implementation in developing countries. ILO 2005.

-10

[www.ec.europa.eu](http://www.ec.europa.eu)

[www.e-skills-conference.org](http://www.e-skills-conference.org)

[www.jointquality.hl](http://www.jointquality.hl)

[www.skills-transfer.net](http://www.skills-transfer.net)

[www.online.onetcenter.org](http://www.online.onetcenter.org)

[www.scotland.gov.uk](http://www.scotland.gov.uk)

[www.elwa.org.uk](http://www.elwa.org.uk)

[www.scqf-org.uk](http://www.scqf-org.uk)

[www.nqai.ie](http://www.nqai.ie)

[www.aqf.edu.au](http://www.aqf.edu.au)

[www.cddd.gotevot.edu.sa](http://www.cddd.gotevot.edu.sa)

[www.gotevot.edu.sa](http://www.gotevot.edu.sa)

\* \* \* \* \*

---

:

---

:

( 2005 ) .

( 2008 ) .

2013

-  
-  
-  
-  
-  
**-1**

4 58 (2009)  
2020 40 2010 %28  
%95 18-15 %60  
(2008 )

%95

2006

( 2008 )

( 2008 )

( ) **1-1**

5-3



---

	(	)		
2010-2005	1000	54	2009	
:				
				%1
	1000	100		
%26	2006		3	
				1999
		%18		
		:		%10
	%76			
				<b>2-1</b>
	(6)	12-6		
7				
	%14	2009		2006
				1999
%40				%81
				2006
	4			%97

---

2015

2009

%25 2006 5.7

%18

%60

12-6

**3-1**

18-12 (6)

28

2009

%60

1999

%24

2006

%59

%52

2006

%68

1999

2005

%92

%48 %73 %70 %76

%73

%42

2005

1999

%96

%69

%97

%78

18-15

(3)

2006

%54

30 2009 2008 395  
%36 2006 7 %48  
2006 %22 1999  
%3.5 %2.4  
%2.5  
2006 %48 %9.4  
%25-20  
2006 %50 %47  
%70 %60  
)  
( 2008

1989 (25)  
)

"

(

:

."



---

. ( 2005 ) .

4/2

. (1) %90  
: (1)

%		
93		1
63		2
55		3
53		4
42		5
33		6
22		7
16		8
4		9
2		10

. ( 2006 ) .%80

---

7444

.819

2006

1035

%12.6

6159

.( 2001 )

**2-3**

7 6

.( )

---

3-3

( )

:(2001)

---

( )

( )



---

-4

أ-

ب-

---

:

) .

(2006).

)

- -

.(

)

(

)

(

---

: :1-9 "92

"  
" 94 1-9  
( )  
." ( .. )

: 2005

- 
- 
- 
- 
- 
- 

%20

.(2000 )

: .(2008 ) %50

.( 2000 )

---

270

1800

2000

900

2007

( )

2008

% 45

%100

%44

% 70

%30

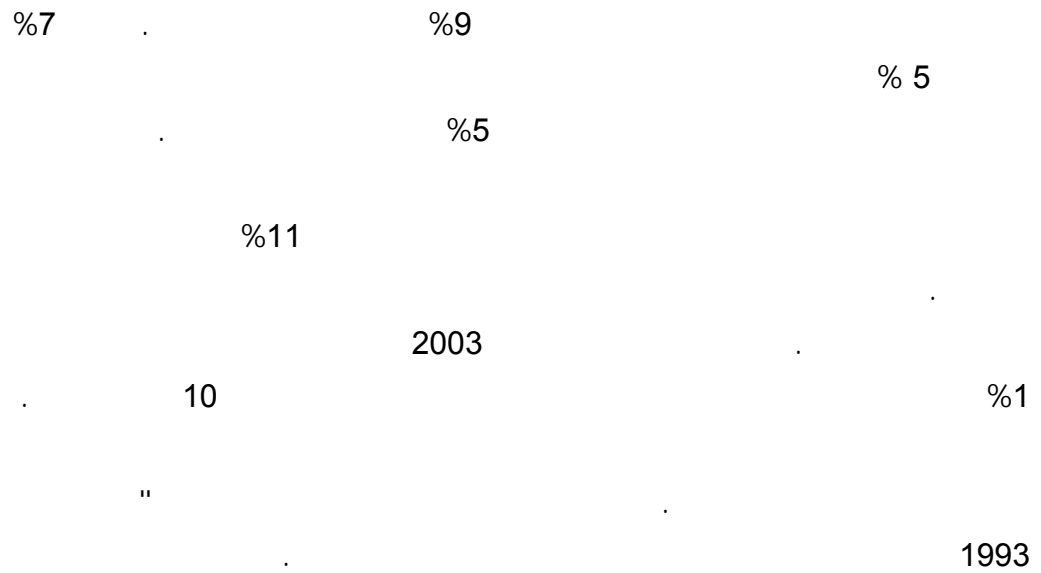

á æ

---

أ-

-

-

أ-

. 2010

:

-1

-2

-3

-4

-5

-6

-7

-8



---

:

:

:

•

•

•

•

:B

---

:B

---

:β

•

•

-

-1

-2

-3

-4

2010

-1

-2

---

-3

-4

-5

-6

-

2010

-1

-2

-3

---

	-4
	-5
	-6
	-1
	-2
	-3
	-4
"	-5

\* \* \* \* \*

		(2005)	-1
	.2005	-	
		(2006)	-2
		(2007)	-3
		(1998)	-4
16	(2001)		-5
		. 2001	
		(2005)	-6
		"	
	. 2005	16-14-	-
		(2008)	-7
		. 2455 :	-
		(2008)	-8
		(2009)	-9
		<a href="http://unesdoc.unesco.org/images/0018/001813/181339e.pdf">http://unesdoc.unesco.org/images/0018/001813/181339e.pdf</a>	
		(2001)	-10
		(2006)	-11
	:(2)	.1296	26 !!
		(2000)	-11
		-	
(3)		(2000)	-12

\* \* \* \* \*

---

:

---

:

" : 1 23

.(Pollis & Schwab,1979:154) "

...

(Sociopolitical)

(Social Bond)

:

-1

: -2

-3

-4

-5

-6

							-1
							-
	(1)						
1990	100	320	2005				
. 1990	%45.5 :	220					
	%2.5						
		.%2.0					%1.5
385	2015	(1)					
	. 2005	%20.3 :	( <sup>1</sup> )				
	( )						
	( )						

<sup>1</sup> المصدر : تقرير التنمية البشرية لعام 2008 ص 231 و 233 .



(1):

2015	2005		
6.9	5.5		1
5.3	4.1		2
0.9	0.7		3
11.2	10.1		4
38.1	32.9		5
1.0	0.8		6
29.3	23.6		7
45.6	36.9		8
23.5	18.9		9
13.0	11.0		10
32.0	28.0		11
3.1	2.5		12
5.1	3.8		13
1.0	0.8		14
1.0	0.8		15
3.4	2.7		16
4.4	4.0		17
7.1	5.9		18
86.2	72.8		19
34.3	30.5		20
3.8	3.0		21
28.3	21.1		22
385	320		

المصدر : تقرير التنمية البشرية لعام 2008 ص 231 و 233 .

15)

(2)

(64 -

(64 - 15)

%60

( ) : (2)

64 - 15	15			
59.5	37.3	2004		1
78.7	20.3	2005		2
70.2	27.3	2005		3
66.5	26.7	2004		4
63.3	32.4	2004	\	5
55.4	41.8	2004		6
64.0	33.2	2005		7
56.0	41.5	2005		8
56.7	39.9	2005		9
49.2	48.4	2004		10
56.2	41.0	2005		11
66.6	31.6	2005		12
50.9	46.0	2005		13
76.3	22.5	2004		14
54.9	42.3	2004		15
56.9	40.2	2005		16
65.3	27.2	2004		17
65.9	30.3	2005		18
63.0	33.2	2005		19
62.7	32.9	2004		20
53.5	43.1	2005		21
50.1	47.3	2004		22
61.0	36.0			

المصدر : تقرير تنمية القوى البشرية في الوطن العربي خلال الفترة 1990 - 2005 ص 38  
في مجالات التربية والثقافة والعلوم

(3)

%76

(<sup>1</sup>) 2005 - 1990

%24

<sup>1</sup> المصدر : تقرير تنمية القوى البشرية في الوطن العربي - الصادر عن المنظمة العربية للتربية والثقافة والعلوم ص 38

(3)

%12.1 : %20

.%17.0 %15.5 % 15.1 %14.7 %14.5

(3)

% 40.7 % 42.2 % 43.4 :

1980 54

2001 101.1

220 2020 120

3.4

.( 2004 16 ) 100 80

( ) :(3)

21.9	78.1	2004		1
14.5	84.5	2003		2
21.7	78.3	2001		3
27.0	73.0	2004		4
17.0	83.0	2004		5
00	00	00		6
15.5	84.5	2002		7
00	00	00		8
15.1	74.9	2005		9
43.4	56.6	2002		10
16.4	83.6	2005		11
22.2	77.8	2003		12
16.4	83.6	2003		13
14.7	85.3	2004		14
42.2	57.8	2002		15
40.7	59.3	2005		16
24.0	76.0	2004		17
24.4	73.6	2004		18
23.0	77.0	2002		19
27.4	72.6	2005		20

30.9	69.1	2000		21
12.1	87.9	2004		22
23.525	75.825			

المصدر : تقرير تنمية القوى البشرية فى الوطن العربى خلال الفترة 1990 – 2005  
فى مجالات التربية والثقافة والعلوم

% 73.5

%39

%60

%9.6

( 25 2009 ) .

:

15

( 2004/9/28 : 13245 ) .

:(4)

45.5	20.7	70.3	2004		1
60.4	*	*	2002		2
62.4	37.1	87.7	2001		3
47.3	25.2	69.4	2004		4
44.65	11.8	77.5	1996		5
*	*	*	00		6
45.6	16.2	75.0	2002		7
45.9	28.2	63.6	1996		8
48.75	15.6	81.9	2005		9
*	*	*	00		10
48.9	20.4	77.4	2005		11
41.7	18.7	64.7	2003		12

40.5	13.4	67.6	2005		13
66	40.0	92.0	2004		14
73.5	60.0	87.0	2004		15
54.25	41.8	66.7	2005		16
44.05	20.2	67.9	2004		17
40.75	15.7	65.8	1995		18
49.35	23.6	75.1	2005		19
51.4	26.4	76.4	2005		20
46.4	28.3	64.5	2000		21
39	9.6	68.4	2004		22

المصدر : تقرير تنمية القوى البشرية في الوطن العربي خلال الفترة 1990 – 2005  
في مجالات التربية والثقافة والعلوم

-

)

.(268:2004

. 2008/2007

(<sup>1</sup>)

12

)

.(10:2005 78

2009

<sup>1</sup> المصدر : مجلة التدريب والتقنية – أكتوبر 2005 ( السيد / شفيق الجبر )

1973 1996 5%  
 25 - 15 15%  
 2004/9/28 10.3% ) 54 - 25 28.4%  
 20 - 21%  
 78 (10:2005 23-24% )  
 : 11%

(5)

	( )						
	%						
	12.70	170,114	58,198	111,916	2008		1
	3.12	85,000	22,500	62,500	2006		2
	4.00	7,810	6,320	1,490	2007		3
	14.10	508,100	174,600	333,500	2007		4
	13.80	1,375,722	280,000	1,095,722	2007		5
	35.24	168,635	-	-	2007		6
	5.63	463,313	167,719	295,594	2007		7
	17.30	2,079,806	-	-	2006		8
	8.42	454,800	217,465	237,335	2007		9
	34.70	1,727,568	-	-	2007		10
	17.50	1,610,297	-	-	2006		11
	6.70	70,668	-	-	2007	( )	12
	21.50	183,000	28,120	154,880	2007		13

	2.40	13,200	-	-	2007		14
	1.33	25,000	13,000	12,000	2006		15
	15.00	187,000	130,900	56,100	2007		16
	18.15	298,500	-	-	2007		17
	9.04	2,188,000	1,083,650	1,104,350	2008		18
	9.60	1,092,000	316,876	775,124	2008		19
	33.20	421,909	-	-	2007		20
	18.46	855,000	253,000	602,000	2007		21

2010

:

-2

-

2006 2000  
%10.34  
12 6

%14

.%15.25

.(8 :2002

) %27

-277:2004 ) %31.7

1421

.(278

2000 / 1421

: (6)

5986985	3043766	2943219	
5713345	3009974	2703371	
273640	33792	239848	
% 4.6	%1.1	%8.15	

2001 / 1422

:(7)

6089767	3060095	3029672	
5808615	3031642	2776973	
281152	28453	252699	
% 4.6	%0.93	%8.34	

2002 / 1423

:(8)

6241656	3092934	3148722	
5913010	3068418	2844592	
328646	24516	304130	
% 5.3	%0.8	%9.7	

2003 / 1424

:(9)

6646368	3324073	3322295	
6279920	3298041	2981000	
367327	26032	341295	
% 5.53	%0.8	%11.45	

2004 / 1425

:(10)

7077326	3572183	3505143	
6669598	3544294	3125304	
407728	27889	379839	
% 5.8	%0.8	%11.0	

2005 / 1426

:(11)

7536228	3838487	3697741	
7083454	3808339	3275115	
452774	30148	422626	
% 6.0	%0.8	%11.43	



2006 / 1427

:(12)

8024885	4124294	3900591	
7522984	4091410	3431574	
501901	32884	469017	
% 6.25	% 0.79	% 12.00	

:(13)

%		%		
	25329		228625	1999
33.40	33786	4.91	239854	2000
15.80-	28453	5.36	252699	2001
13.84-	24513	20.35	304133	2002
6.2	26032	12.22	341295	2003
7.1	27889	11.3	379839	2004
8.1	30148	11.3	422626	2005
9.1	32884	11.00	469017	2006

(

)

-

( )

( )

(14)

%77.3 : 2,080,663 1999

%88.4 : 4738823 2005

(14)

2006

1999

(13)

(15).

(14):

%	%				
77.3	22.70	2,691,440	2,080,663	610,777	1999
76.95	23.00	2,810,901	2,163,117	647,784	2000
76.6	23.40	2,940,849	2,253,588	687,261	2001
*	*	*	*	*	2002
88.5	11.5	5128075	4536460	591615	2003
89.5	10.45	4648530	4162804	485726	2004
88.4	11.6	5362288	4738823	623465	2005

(8) :

2001

(15):

Total	Non Saudi	Saudi	
65,139	12,521	52,618	
549,207	450,071	99,136	
57,347	19,260	38,087	
461,106	414,178	46,928	
1,048,749	790,649	258,100	
163,412	137,581	25,831	
141,643	89,992	51,651	
38,659	17,877	20,782	
32,054	15,937	16,117	
196,975	162,639	34,336	
43,818	29,669	14,149	
73,314	58,475	14,839	
69,426	54,739	14,687	
2,940,849	2,253,588	687,261	

%3.0

(16)

. 2005 1991

:(16)

%			
2005	1991		
4.9	8.0		1
1.3	2.0		2
**	3.9		3
7.3	6.0		4
**	5.1		5
7.9	3.5		6
6.8	5.8		7
**	6.0		8
**	3.9		9
**	**		10
**	**		11
3.6	3.0		12
**	**		13
1.6	3.5		14
3.9	**		15
5.1	4.8		16
2.6	**		17

2.7	**		18
**	3.9		19
6.7	5.0		20
2.3	4.6		21
9.6	**		22
3.0	3.1		

. 284 - 282 2008 / 2007 :

340

200

1300

6500

"

% 50

"

.)

.( 1422

---

-4

( )

-5

(20:2002 )

( )

( )

" "

" "

---

( )

" "

-6

:

-

-

-

-

( )

-

National Center for Employment) ( )

-

(Arab

...

-

-

\* \* \* \* \*

---

			■
		(2004)	-1
	: .295-263:(2) 32	.	
-13:(1)26	.	(2002)	-2
		: .81	
(78)	.	(2005)	-3
		: . 1426	
	: .	( 1427)	-4
			■

- 5- Pollis, A. & P. Schwab (1979). Human Rights: Cultural and Ideological Perspectives. New York: Praeger Publishers.

\* \* \* \* \*





---

:

---

:

% 0.7

-1

1-1

..'(105 )'

': ..(21 ).'

' ..'

':

..'

..'

( )

" (9:18 ) "

"

.(11:12 ) "

---

" (17:4) "

" (12:4) "

( )

2-1

1

" "

-

"

"

1

1

1

1

(1986-1975)

-

1

1974

1973

---

1

"

"

"

"

-

(

)

:

-

1

-

1



-

( )

1

( )

-

1

-

1

-

:

-

1

-

1

-

1

-



Table with 2 columns and 10 rows. The first column contains text fragments including colons, parentheses, and ellipses. The second column contains dashes. Some cells in the first column contain the number '1'.

:	-
( )	-
.	-
.	-
...	-
.	-
.	-
.	-
:	-
1	-
1	-
	1 -
1	-
1	-
1	-

---

-2  
1-2

( )

( ) ( )

2-2

:

1

1

( )

- 
- 
-



" "

(Cognitive Competencies)

" "

:

"

"

1

1

1

■

■

■

■

---

" " ...

" " :

æ

(Self Development)





4755

10 .2008 5858 2007  
 %10 2008 %20  
 .(2) .%5.3

2008/2007

:(2)

%	2008	2007	
2008-2007			
21.9	70651	57946	
20.0	52574	43815	
25.0	43046	34431	
22.0	21668	17754	
37.7	20898	15180	
19.3	18898	15835	
16.4	10520	9038	
17.5	7466	6353	
23.2	5858	4755	
24.8	4916	3939	
13.5	3959	3487	
22.2	3630	2971	
47.9	3611	2442	
25.8	2677	2128	
12.4	2632	2342	
22.4	2192	1791	
5.3	1599	1519	
16.8	1181	1011	
12.3	1131	1007	
25.2	1128	901	

2009

### 3.3

2005 1.25 %3.6 1999 %4.2  
 11  
 2005 %16.9  
 - (3)  
 51  
 :(3)

%				/
2		1.25		
/		/		
2005	1999	2005	1999	
39.6	61.5	18.0	35.5	
9.3	15.0	4.1	5.6	
16.9	21.2	7.9	10.5	
16.9	18.9	3.6	4.2	
73.9	77.3	40.4	44.1	
72.9	77.6	51.2	58.2	/
47.3	57.1	25.7	33.7	

### 4.3

2006-1999  
 %80 2006  
 %48 %22  
 .%82.3 32.8  
 20

---

					-
.%48	2006	%58			
		.%7			
					-
2006	10.9	(	)		
		10.8		10.2	
					-
% 26.3	% 29.9	% 40.5	% 55.4	2005	
		2005 - 1999		.% 25.7	
					-
2006	%28.1	(	15)		
			.%13.9	( 24-15	)
					<b>5.3</b>
supply )			(demand driven)		(driven
%20					

%5

%20

(4)

:(4)

(%)	(%)	
64	36	
68	32	
60	40	
65	35	
78	22	
56	44	
50	50	

6.3



: (5)

	( )						
%100	----	0.7	83.8	8.9	6.6	2007	
%100	3.1	0.0	87.1	7.3	2.5	2006	
%100	----	34.3	90.0	3.6	6.1	2008	
%100	14.3	5.0	59.7	15.3	5.8	2007	
%100	15.5	18.1	47.2	19.1		2005	
%100	6.5	26.3	42.3	18.7	6.3	2007	
%100	5.6	0.1	87.6	4.8	1.9	2007	
%100	2.3	16.7	35.6	39.9	5.4	2006	
%100	8.4	8.1	49.2	26.4	7.8	2007	
%100	9.0	28.3	31.3	22.2	9.2	2005	
%100	----	34.3	33.2	23.2	9.2	2007	
%100	6.5	0.2	84.2	7.1	2.0	2007	
%100	21.6	8.7	46.5	19.6	3.6	2007	
%100	-----		99.3	0.7		2007	
%100	1.3	----	94.2	2.4	2.1	2006	
%100	15.0	3.6	52.9	24.2	4.3	2007	
%100	18.9	0.1	69.0	10.9	1.0	2006	
%100	8.9	12.8	53.3	12.1	12.9	2007	
%100	0.2	32.2	38.6	26.1	2.9	2006	
%100	6.1	26.3	38.6	23.2	12.2	2007	
%100	18.5	8.0	49.5	20.3	3.7	2007	

( )

%30

%60

%50

%11

5

%65 %30  
%63 %40 %35 %30

2.4

. 2000  
.2007 %5.7  
.2008-2004 (6)  
:(6)

2008-2004

2008	2007	2006	2005	2004	
6.0	5.7	6.0	6.2	6.3	
6.4	5.7	6.3	6.9	7.2	
8.8	8.5	9.1	9.2	9.7	( )
3.8	3.5	3.6	3.8	3.8	
5.7	5.5	6.2	6.1	6.4	
5.4	5.3	5.3	5.4	5.3	
7.3	7.2	7.4	7.9	8.2	
9.4	9.4	9.8	9.8	9.2	
10.3	10.4	10.5	11.6	11.9	
7.9	7.9	81	8.1	8.2	

2009

4

%56.6

%28.1

%63

.2007



%33.6  
 2007      %25.2      1995  
 -  
 %30      24-15  
 %26.8      %14.4  
 %94      %17.7      %19.3  
 29-15  
 -  
 146  
 %3.4      %2.3      2020  
 2020      40  
 2008      (1)

الشكل (1): التوزيع النسبي لفرص العمل المستحدثة في عام 2008

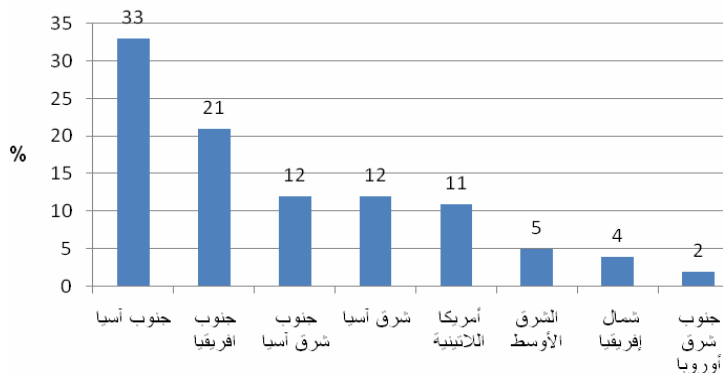

2008

:

/  
1(%0.7)

:

1

•

•

1

•

:

•

•



---

2.5

( )

:

1

1

1

( )

Occupational Outlook

■	■		■	
■	■		■	
			■	
	-			
	-			
	-			
		(	)	

■

■

●

:



/

/

•

•

■

1

•

•

1

1

•

•

-

■

•

1

•

1

•

1

•

1

•

•

1

1

•



---

		■
	General Aptitudes Test Battery	●
1		
	Vocational Aptitudes Test Battery	●
		1
	1	●
2008	Occupational Outlook	●
	1	●
		1
	1	●
1		●
		●
1	/	●
		●
		<b>3.5</b>

---

Quality)) -

( )

: -

Relevancy

.External Efficiency

\_\_\_\_\_

\*

\*

:( ) -

( )

( )

Adjustment

( )

\_\_\_\_\_

\*



---

\*

: -

Effectiveness

Institutional based

\_\_\_\_\_

\*

(Combined)

:

On – The – Job) )

: ( ) -

Responsiveness

\_\_\_\_\_

•

---

Retraining \*

Updating \*

Upgrading \*

\*

: -

Balancing

---

\*

\*

\*

projection

labor Market Management Information System \*

**4.5**

---

99-20 .( ) 19-5 4-1 :  
: 100

1 1 1

Running / Start Pre - start :  
.Grow and Development /

/ 24-15  
â

1

•

•

:

\*

\*

"

"



\_\_\_\_\_ : \_\_\_\_\_ .( ) \_\_\_\_\_  
/ /

: ●

“ ”

: ●

( / ) : \*

: \*

( / ) : \*

\*

- - : / ●

o

: ●





---

) / : •  
.  
(  
■  
:  
/  
.  
.  
•  
•

\* \* \* \* \*

